

ECC/B PUMP RANGE

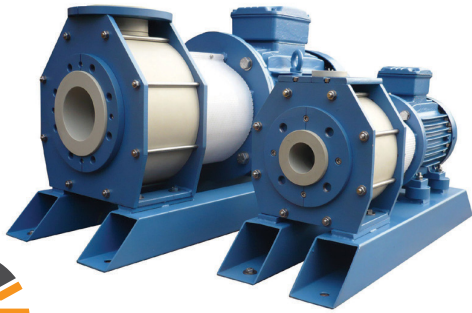

HORIZONTAL END SUCTION, **MECHANICALLY SEALED**, CENTRIFUGAL PUMPS



**MANUFACTURED
IN THE UK**

- ∞ CAPACITY <300 M³/HR
- ∞ HEAD <80Metres
- ∞ DESIGNED TO ISO2858
- ∞ HEAVY DUTY DESIGN
- ∞ CLOSE OR LONG COUPLED
- ∞ FLEXIBLE DESIGN TO YOUR SPEC
- ∞ HIGH EFFICIENCY

Part of the
MECHANICAL SEAL
Pump Range



PP

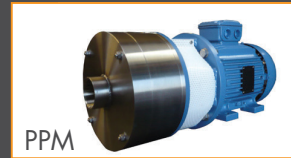

PPM



ECC

∞ ECC/B OVERVIEW

Designed to ISO2858 the ECC (close coupled) & ECB (long coupled) are dimensionally compatible with any other ISO designed pump so are readily interchangeable without having to modify existing pipework. Plastic parts are available in a wide choice of materials including Polypropylene, PVC, PVDF & PTFE (some sizes) and with many mechanical seal options, this flexible approach ensures that you will have the correct combination to exactly match your specific application.

There are no moulded parts in our pumps and all plastic parts are machined from solid ensuring greater strength and rigidity in extreme and hazardous environments, plastic parts are supported by a robust steel shell absorbing any outside pipeline forces. Crest have been manufacturing pumps since 1973 and all pumps leave our works with a 24 month warranty. In addition, we have a NO OBSOLETE PARTS policy ensuring that your pump will have a long and trouble free life.

∞ UK MANUFACTURED

Every ECC/B pump is designed and manufactured by Crest in the UK which means we have the facility to tailor pumps to your exact requirements, whether this be a specific cartridge seal configuration or the pump built to match your specific dimension requirements. We can supply a pump that is exactly right for you.

∞ SATISFACTION GURANTEED

There are Crest Pumps installed across the world, in numerous applications, and with some of the largest global companies including BASF, GlaxoSmithKline and General Electric amongst many others. Outstanding service is our top priority and we will do everything we can to make sure we recommend to you the best pump at the right price, delivered on time and backed up with attention to detail after sales support.



**2 YEARS
WARRANTY**



**ATEX ZONE 1/2
CERTIFIED**



**FLEXIBLE TO
DESIGN SPEC**



**CHOICE OF
MATERIALS**



**CORROSION
RESISTANCE**



**NO OBSOLETE
PARTS POLICY**

PLASTIC MECHANICALLY SEALED PUMPS

Prime Fluid Management

0800 482 747

info@primefluid.co.nz | primefluid.co.nz

ECC/B PUMP RANGE

HORIZONTAL END SUCTION, **MECHANICALLY SEALED**, CENTRIFUGAL PUMPS

RANGE CURVES

Pump curves for the mechanically sealed ECC/B Pump Range.

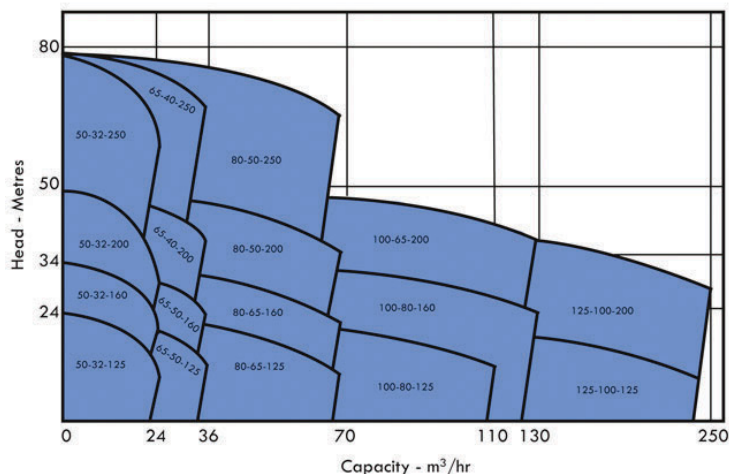

INFORMATION

CHEMICAL COMPATIBILITY TABLE

Download, print and use our free chemical compatibility table for information on material resistance against corrosive materials.

FREE CONVERSION TOOLS

m³/hr to L/min, Bar to meters. We provide free and easy to use conversion tools on our website for flow, pressure, distance and more.

www.crestpumps.co.uk

TECHNICAL SPECIFICATION

MODEL	SUCTION (mm)	DIS-CHARGE (mm)	SPEED (rpm)	RATED CAPACITY (m ³ /hr)	RATED HEAD (m)	MAX CAPACITY (m ³ /hr)	MAX HEAD (m)	MOTOR OUTPUT (kW)
50-32-125	50	32	2900	16	16	24	22	2.2
50-32-160	50	32	2900	16	26	26	24	4
50-32-200	50	32	2900	16	40	20	50	7.5
50-32-250	50	32	2900	16	72	20	80	15
65-50-125	65	50	2900	24	20	35	22	2.2
65-50-160	65	50	2900	24	31	36	36	4
65-40-200	65	40	2900	24	44	36	54	11
65-40-250	65	40	2900	24	76	36	80	15
80-60-125	80	65	2900	45	18	69	22	5.5
100-65-200	100	65	2900	74	42	110	52	22
100-80-125	100	80	2900	80	18	110	22	11
100-80-160	100	80	2900	100	25	124	36	18.5
125-100-160	125	100	2900	150	24	230	32	30
125-100-200	125	100	2900	180	36	250	54	37
100-80-315	100	80	2900	40	25	60	32	5.5
125-100-250	125	100	2900	75	20	125	21	705
150-125-200	150	125	2900	200	12	270	16	15
150-125-250	150	125	2900	200	18	240	23	18.5

ECC/B PUMP RANGE

HORIZONTAL END SUCTION, **MECHANICALLY SEALED**, CENTRIFUGAL PUMPS

RANGE DIMENSIONS

For specific 3D CAD drawings or specific pump dimensions, please contact us at info@crestpumps.co.uk or telephone +44 (0)1425 627700.

NOTE:

1. The total length and weight of the pump will differ depending on the brand of the motor.
2. All dimensions are in mm.
3. Assembly tolerances are +/- 3mm.
4. Pump length and size depends on motor type and brand *
5. All holes are equal to 4 holes at 19 mm diameter **

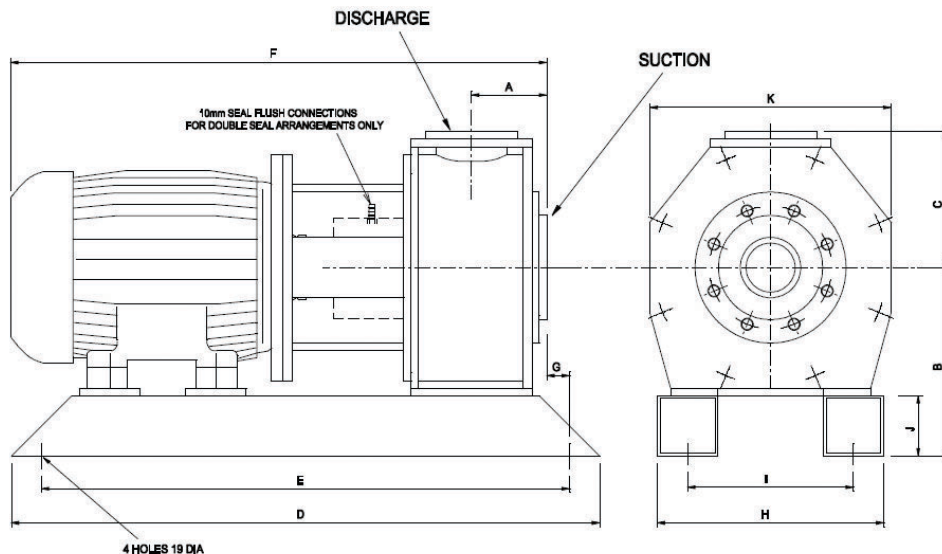

MODEL	A	B	C	D	E	F	G	H	I	J	K	L
50-32-125	80	202	140	*	*	*	27	260	180	80	260	**
50-32-160	80	222	160	*	*	*	30	300	220	80	300	**
50-32-200	80	250	180	*	*	*	30	300	220	80	300	**
50-32-250	100	270	225	*	*	*	30	370	240	80	370	**
65-50-125	80	202	140	*	*	*	27	260	180	80	260	**
65-50-160	80	222	160	*	*	*	27	260	180	80	260	**
65-40-200	100	250	180	*	*	*	27	320	240	80	320	**
65-40-250	100	270	180	*	*	*	30	320	240	80	320	**
80-65-125	100	250	160	*	*	*	30	320	240	80	320	**
80-65-160	100	250	180	*	*	*	30	300	260	80	300	**
80-50-200	100	250	200	*	*	*	30	320	240	80	320	**
80-50-250	125	270	225	*	*	*	33	320	240	80	320	**
100-80-125	100	250	180	*	*	*	30	320	240	80	320	**
100-80-160	100	250	200	*	*	*	30	320	240	80	320	**

ECC/B PUMP RANGE



HORIZONTAL END SUCTION, **MECHANICALLY SEALED**, CENTRIFUGAL PUMPS

CASE STUDY - CHINOOK SCIENCES

“Chinook ensured safety and reliability of their new metal recycling plant with the ECC/B and AMX pump range from Crest Pumps”

Chinook Sciences has created the world's most efficient energy-from-waste technology, enabling major recyclers and waste handlers to recover valuable metals and create energy from waste previously considered unrecyclable.

Their unique gasification system harnesses thermal power to reclaim metals and generate low carbon energy.

Rodecs converts 99% of hydrocarbons in the waste into renewable energy (in the form of synthetic gas or 'syngas'), recovering up to 1.24MW per tonne of waste processed.

The system powers itself using gas and heat emitted during the process, with surplus energy used to generate electricity or sold to the National Grid.

Crest Pumps has provided a number of magnetic drive and mechanically sealed plastic pumps as part of the scrubbing systems to remove all particulates and pollutants from the syngas. The pumps were constructed from polypropylene and suitable for pumping acids up to 5 bar pressure.



CREST PUMPS - UTILISED BY



APPLICATIONS



CHEMICAL

Chemical application include chemical transfer, dosing, re-circulation, filtration, fume scrubbing and tanker off-loading.



PETROCHEMICAL

Previous petrochemical installations include high temperature, high pressure, highly viscous applications as well as chemical injection, re-circulation, off-loading and solid handling.



WATER TREATMENT

Providing reliable process pumps to the UK's largest waste-water treatment providers, for chemical transfer, desalination, reverse osmosis, water treatment and tanker unloading.



PHARMACEUTICAL

Pharmaceutical companies have relied on Crest Pumps to provide pumps for ATEX requirements, chemical injection, CIP pumping, solid handling, high viscous medias and highly toxic applications.



BIOFUELS

Fully ATEX certified process pumps for transfer of liquids in explosive atmospheres, solids handling, tanker unloading, recirculation and transfer.



ENERGY GENERATION

Pumps supplied for various energy generation applications, including wind turbine, solar, and Vanadium redox flow batteries.



MARINE

Centrifugal pumps supplied for various below deck applications including ballast water treatment, electrolysis, desalination and sea water cooling systems.

PLASTIC MECHANICALLY SEALED PUMPS

Prime Fluid Management

0800 482 747

info@primefluid.co.nz | primefluid.co.nz