

5

B, BC, MBM, MBMC Series

Gear Pumps with Bare Shaft
and Feet Mounting,
Gear Pumps on Skid with Motor,
Heating Chamber Version,
ATEX version.

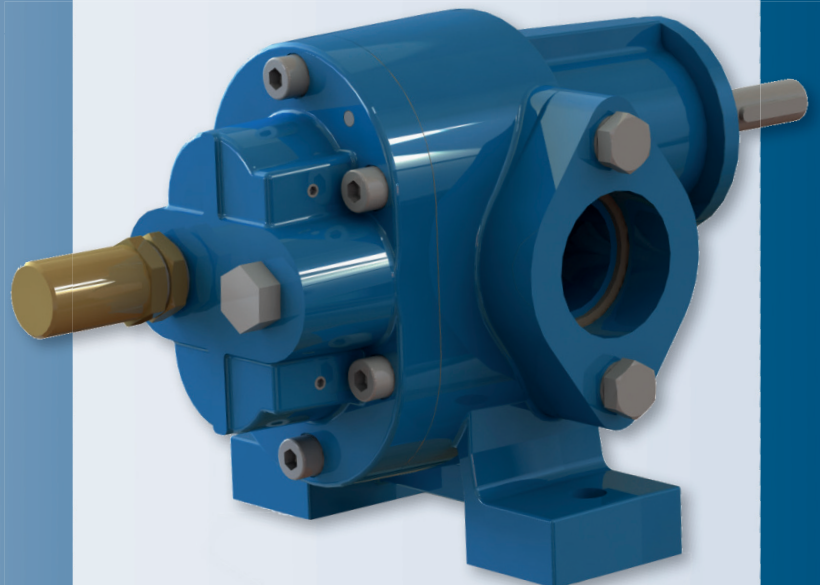

Supplied by
Prime Fluid Management

5.1 MAIN CHARACTERISTICS AND NOMINAL FLOW RATES

B, BC, MBM, MBMC pumps are volumetric gear pumps suitable for transferring lubricant viscous liquids without any suspended solids or abrasive substances. They are self-priming pumps used for a wide range of liquids with a viscosity from 1 to 20000 cSt. The speed of rotation is chosen according to the viscosity of the liquid. Flowrate range is from 5 to 800 L/min.

The standard construction consists of pump housing and cover in cast iron, shafts and gears in carbon steel, gaskets in Flexoid, sleeve bushings in Steel-Bronze-PTFE and a mechanical seal in ceramic-graphite-Viton. These pumps are supplied with a pressure relief valve in brass.

Nozzles in inlet and outlet are of the same diameter and positioned on the same axis.

A short and straight alignment of the flow channels provides for a good suction capability and a quiet running. The helical gears result in extremely low noise levels and reduced pressure pulsation.

B, BC pumps are typically installed on a skid and driven by an electric motor by means of an elastic coupling (MBM, MBMC series). The sizes from 10 to 400 are also available with a heating chamber integrated in the pump housing (BC, MBMC series).

Fig. 501 – B pump, standard version

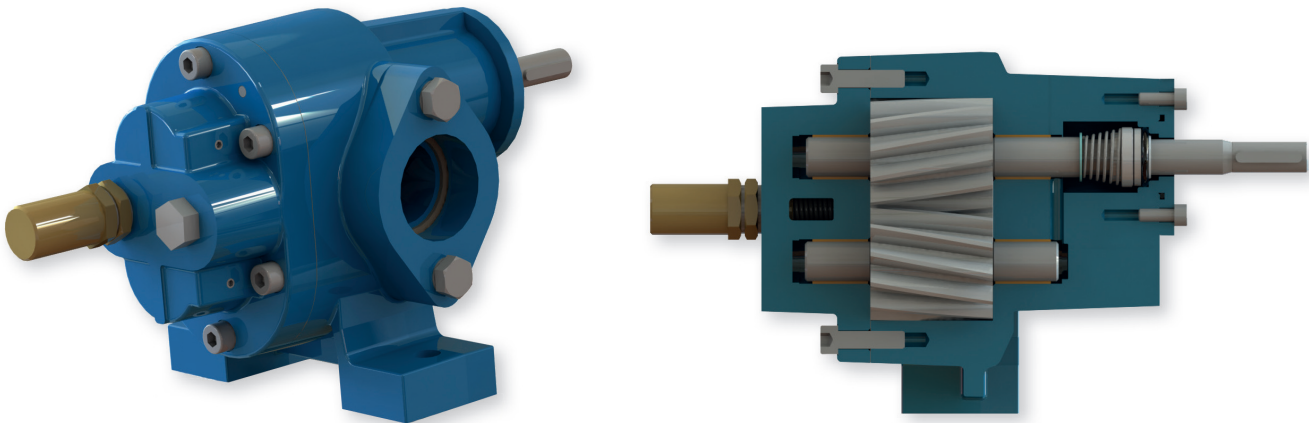

Table 501 shows the possible flow rates for non-pressurized pumping ($\Delta p=0$) and a 46 cSt fluid. The flow rate of gear pumps is virtually proportional to their

speed. The selected speeds are the most common speeds at rated power of industrial electric motors at 50 and 60Hz.

Tab. 501 – Nominal flow rates

PUMP SIZE (B, BC, MBM, MBMC)	Geometrical displacement V_{geo} [cm ³ /rev]	Nominal flow rate Q_{te0} [L/min] at Speed n [1/min]					
		690	830	950	1150	1450	1750
5	4.6	3.1	3.8	4.3	5.2	6.6	8.0
10	9.1	6.3	7.5	8.6	10.5	13.2	15.9
15	13.6	9.4	11.3	12.9	15.7	19.8	23.9
25	18.2	12.5	15.1	17.3	20.9	26.4	31.8
40	28.1	19.4	23.3	26.7	32.3	40.7	49.1
50	41.2	28.4	34.2	39.1	47.3	59.7	72.0
70	50.3	34.7	41.8	47.8	57.9	73.0	88.1
100	81.4	56.1	67.5	77.3	93.6	118.0	142.4
150	117.5	81.1	97.5	111.7	135.2	170.4	205.7
200	149.5	103.2	124.1	142.1	172.0	216.8	
250	185.4	127.9	153.9	176.1	213.2	268.8	
300	221.3	152.7	183.7	210.2	254.5	320.9	
350	257.2	177.5	213.5	244.3	295.8	372.9	
400	299.1	206.3	248.2	284.1	343.9	433.6	
500	369.6	255.0	306.8	351.1	425.1	535.9	
550	407.9	281.4	338.5	387.5	469.0	591.4	
600	446.1	307.8	370.3	423.8	513.0	646.8	
1200	885.5	611.0	734.9				
1600	1201.7	829.2	997.4				

5.2 MAIN OPTIONS

The main options available are:

- Counter-clockwise rotation (see paragraph 5.3)
- Options on relief valve (see paragraph 5.4)
- Special seals according to liquids and temperatures (see paragraph 5.5)
- On skid with electric motor (see paragraph 5.6)
- Constructions for corrosive liquids and aggressive environments (see paragraph 5.7)
- Heating solutions (see paragraph 5.8)
- Atex (see paragraph 5.9)
- Accessories (see paragraph 5.10)

5.3 SENSE OF ROTATION AND FLOW DIRECTION

The standard version of B and BC pumps can operate only in one direction of rotation: clockwise watching the pump shaft-end.

The direction of the fluid flow is shown by an arrow placed nearby the piping connections.

A proper mounting will keep the nameplate on the top side. The flow direction will be from the left side to the right-side watching the pump shaft-end and the pressure side (delivery) will be at the right side.

On request a counterclockwise version can be supplied.

Fig. 502 – B, BC Series - Sense of rotation and flow direction

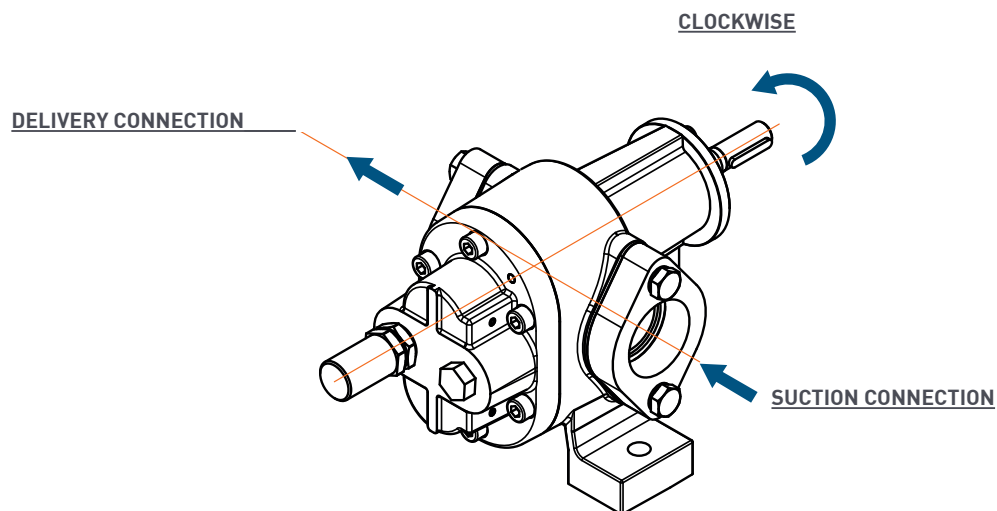

The standard version of MBM and MBMC pumps can operate only in one sense of rotation: clockwise watching the electric motor fan.

The sense of rotation of the motor, when properly connected to the mains, is shown by an arrow placed on

the fan cover. Watching the electric motor fan, the flow direction will be from the left side to the right side and the pressure side (delivery) will be at the right side.

On request a counterclockwise version can be supplied.

Fig. 503 – MBM, MBMC Series - Sense of rotation and flow direction

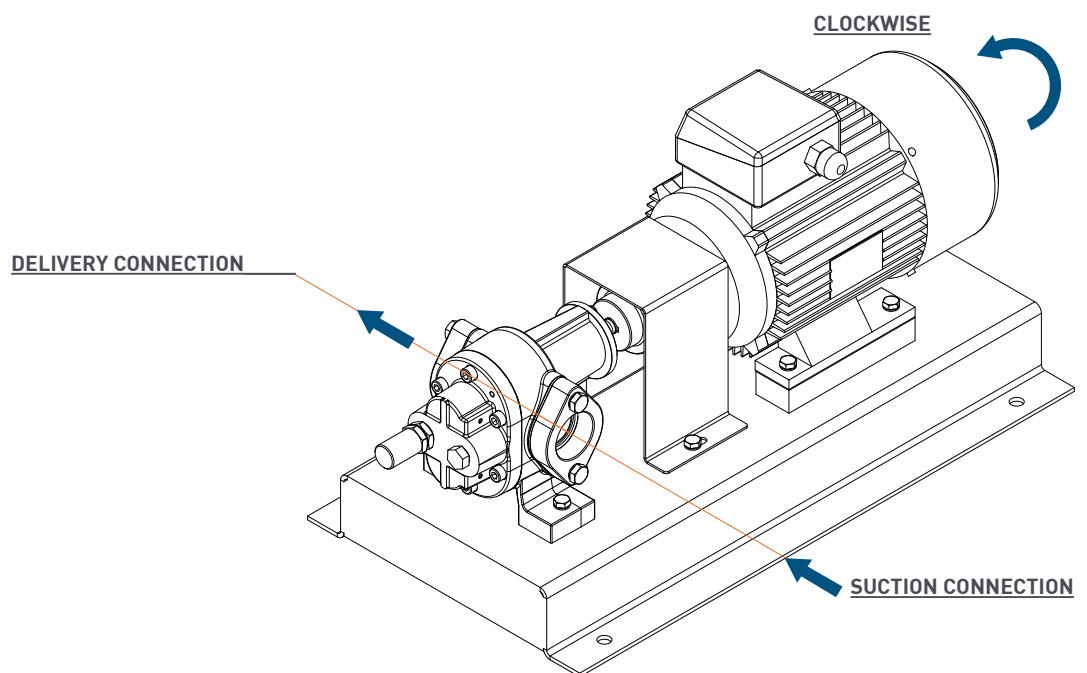

5.4 PRESSURE RELIEF VALVE

B, BC, MBM, MBMC pumps are supplied with a brass pressure relief valve as a standard. It works only on outlet, in one direction.

It may be used as a safety valve only for short-term operations. When a partial discharge flow has to be drained over a prolonged period of time, a separate by-pass valve with return to the suction tank has to be installed into the piping.

The pressure relief valve is designed as a spring-preloaded

piston valve. It is integrated into the pump's end cover. The spring pretension and the relative opening pressure can be adjusted by means of a screw. Different springs are also available to reach the desired adjustment range.

The pressure relief valve is available on request in stainless steel construction.

As an option the pumps can be supplied without relief valve.

5.5 SHAFT-END SEALS

The standard version is fitted with mechanical seal in ceramic-graphite-FPM. A number of different seals materials can be supplied for different liquids and operating temperatures.

On request:

- Radial lip-type seal in FPM (Viton), NBR or PTFE (Teflon)
- Packing seal in Acrylic yarn-PTFE
- Seal for high temperatures up to 200°C
- Reversible mechanical seal
- Double mechanical seal; available also with flushing system or quench

Fig. 504 - Mechanical seal

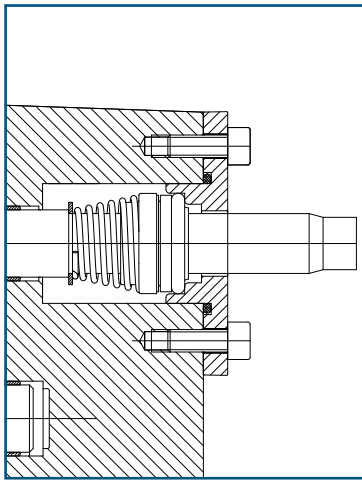

Fig. 505 - Lip seal

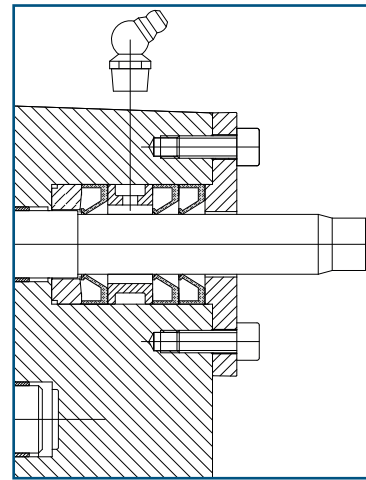
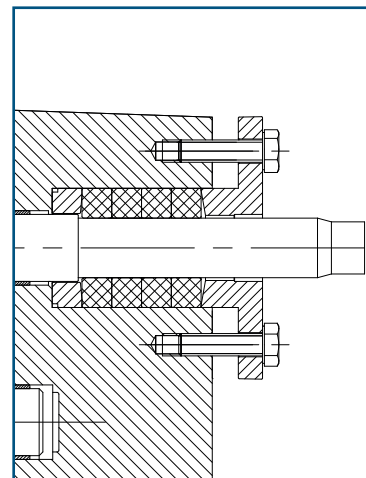

Fig. 506 - Packing seal



5.6 SKID VERSION WITH ELECTRIC MOTOR AND COUPLING (MBM, MBMC)

B, BC pumps can be mounted on a skid in galvanized steel and coupled to electric motors of different sizes through elastic coupling. Motors must be in frame B3.

The group is called MBM (B pump and motor on skid) and

MBMC (BC pump and motor on skid).

In table 502 the most common combinations of pumps and electric motors are listed.

Tab. 502 - Combinations of pumps and electric motors

PUMP SIZE (MBM, MBMC)	IEC Frame size									
	71	80	90	100	112	132	160	180	200	225
	Maximum rated power for a 4 poles motor at 400V/50Hz [kW]									
	0.37	0.75	1.50	3	4	7.5	15	22	22	30
5										
10										
15										
25										
40										
50										
70										
100										
150										
200										
250										
300										
350										
400										
500										
550										
600										
1200*										
1600*										

(*) 8 poles for pump models MBM1200 and MBM1600

The most common installed electric motors have the following characteristics:

- Standard motors in IP55, insulation class F available at 4, 6 and 8 poles
- Standard voltages for Three-phase motors $\leq 4\text{kW}$
230/400V 50Hz - 265/460V 60Hz
- Standard voltages for Three-phase motors $\geq 5,5\text{kW}$
400/690V 50Hz - 460/795V 60Hz
- Standard voltages for Single-phase motors 230V 50Hz

Special options on electric motors:

- Atex motors (see paragraph 5.9)
- Motors with built-in frequency converter
- Motors suitable for frequency converter connection
- Motor with forced ventilation

- Tropicalization
- Special voltages
- Protection IP56/IP65
- Protection IP67/IP68
- Thermistors PTC
- Special treatment for corrosive and saline environment
- Motors according to UL-CSA, NEMA, cURus and Marine regulations
- Insulation class H

Special motors available:

- Internal combustion engines
- Gearmotor
- Mechanical variator
- DC motors at 12V and 24V

5.7 VERSION FOR AGGRESSIVE LIQUIDS AND ENVIRONMENTS

B, BC, MBM, MBMC pumps can be supplied in a corrosion and acid-resistant construction.

Stainless-steel version

Pump housing, cover, shaft and gears in stainless steel and sleeve bushings in AISI 316-Bronze-PTFE.

Bronze version

Pump housing and cover in bronze, shaft and gears in stainless

steel and sleeve bushings in AISI 316-Bronze-PTFE.

Seals and gaskets materials are chosen according to the liquid pumped.

Many combinations suitable for corrosive liquids and aggressive environment can be supplied as follows:

- Gears in bronze
- Sleeve bushings in PTFE or Tecapeek

5.8 VERSION WITH HEATING CHAMBER (BC, MBMC)

BC pumps, available from size 10 to 400, have got a heating chamber integrated in the pump housing.

BC pumps are useful when the pumped liquid (such as bitumen or wax) needs to be heated in order to prevent the liquid from hardening. The heating chamber works with a circulation of diathermic oil, hot water or saturated vapor.

A different heating solution, as an alternative to the heating chamber, is to provide holes for glow-plug or electric resistances (not included).

MBMC serie consists in a BC pump mounted on a skid and coupled to electric motor by means elastic coupling.

5.9 VERSION FOR HAZARDOUS AREAS (ATEX)

5.9.1 The Atex Directives

ATEX is an abbreviation for "ATmosphere EXplosible" and refers to the following two European Union Directives:

- the Directive 2014/34/EU, for equipment and protective systems intended for use in potentially explosive atmospheres, is mandatory for manufacturers and states the classification criteria (ATEX CATEGORIES) and the manufacturing, marking and certification rules for such products;
- the Directive 99/92/EC, for the minimum requirements for improving the safety and health protection

of workers potentially at risk from explosive atmospheres, is mandatory for employers and states the classification criteria (ATEX ZONES) for working places where could happen a potentially explosive atmosphere. This Directive set also the connection between ATEX ZONES and ATEX CATEGORIES.

The Directive 2014/34/EU has replaced the former ATEX 94/9/EC and states that the electric products and the mechanical products, pumps included, intended to be used in hazardous areas, must be designed and manufactured in order to avoid being themselves a source of ignition.

Tab. 503 – Atex Categories according to Directive 2014/34/EU

Protection level (Guaranteed by the equipment Category)	Mine	Surface	
		Gas	Combustible dust
Very High	M1	1G	1D
High	M2	2G	2D
Normal	not provided for	3G	3D

Tab. 504 - Atex Zones according to Directive 99/92/EC

Hazardous level of the perational Zone Explosive atmosphere	Usage area in the presence of	
	Gas	Combustible dust
Always present	Zone 0	Zone 20
Probable	Zone 1	Zone 21
Unlikely	Zone 2	Zone 22

Tab. 505 - Association Zone and Category according to Atex 99/92/EC – gas

Explosive atmosphere	Danger zone	Protection guaranteed by equipment	Equipment category
Always present	0	Very High	1G
Probable	1	High	2G
Unlikely	2	Normal	3G

Tab. 506 - Association Zone and Category according to Atex 99/92/EC – dust

Explosive atmosphere	Danger zone	Protection guaranteed by equipment	Equipment category
Always present	20	Very High	1D
Probable	21	High	2D
Unlikely (conductive dusts)	22	Normal	2D
Unlikely (non conductive dusts)	22	Normal	3D

5.9.2 The Atex pumps features

The Atex version of pumps B, BC on skid with Atex electric motor coupled with elastic coupling, (Atex electric pumps MBM, MBMC), is available for surface applications Group II (not for mines, Group I).

They belong to the Atex categories

- 2G, 3G for gases and vapours up to Group IIC (hydrogen, acetylene...)
- 2D, 3D for dusts up to Group IIIC (combustible metallic dust)

5.9.3 The Atex pumps conformity and marking

The Atex MBM, MBMC electric pumps comply with the Directive 2014/34/EU and the relevant technical assessment documentation has been filed at INERIS (Notified Body NB0080).

They are marked in conformity with the Directive 2014/34/EU and with ISO EN 80079-36 / 80079-37 standards as follows:

- II 2G Ex h IIC Tx Gb for usage in the presence of gases in Zone 1 and Zone 2
- II 2D Ex h IIIC Txxx°C Db for usage in the presence of dusts in Zone 21 and Zone 22.

The electric motor driving the pump, manufactured in compliance with IEC EN 60079-0, 60079-1, 60079-7 (for gases and vapours) or in compliance with IEC EN 60079-0, 60079-31 (for combustible dusts) matches the pump's protection mode and the customer's requirements.

The temperature class Tx (gases) or the maximum

The Atex MBM, MBMC electric pumps are available

- in all constructions (cast iron, bronze, stainless steel)
- with all shaft-end seals (mechanical, lip ring, packing)
- for ambient temperature between -20°C and 40°C
- for fluid viscosity up to 20.000 cSt
- for maximum fluid temperature of 180°C
- for maximum fluid conductivity of 1000 pS/m

surface temperature Txxx°C (dusts) are mainly linked to the maximum temperature of the pumped fluid. Therefore, the end user is responsible to limit the fluid temperature in order to keep Tx or Txxx°C below the maximum values defined by the Zone classification.

In addition to these electric pumps the Atex bare shaft pumps B, BC are available. They comply with the Directive 2014/34/EU and the relevant technical assessment documentation has been filed at INERIS (Notified Body NB0080).

They are marked in conformity with the Directive 2014/34/EU and with ISO EN 80079-36 / 80079-37 standards as follows:

- II 2G Ex h IIC Tx Gb for usage in the presence of gases in Zone 1 and Zone 2
- II 2D Ex h IIIC Txxx°C Db for usage in the presence of dusts in Zone 21 and Zone 22.

5.10 ACCESSORIES

- Pump on trolley
- Special tank for liquid container
- Control panel
- ON/OFF switches
- Reversing switches
- Piping
- Heated piping
- Valves
- Pressure gauge and pressure switch
- External cooling system
- Electric cables

5.11 SOUND LEVEL

The sound level has been measured in dB(A) at 1m distance, at 1450 1/min with gear oil (viscosity 46 cSt).

Tab. 507 – Sound level

PUMP SIZE (B, BC, MBM, MBMC)	Sound level dB(A) at pressure			
	2 bar	5 bar	10 bar	12 bar
5	66.0	66.0	68.0	68.0
10	66.0	66.0	68.0	68.0
15	66.0	66.0	68.0	68.0
25	66.0	66.0	68.0	68.0
40	75.4	77.0	77.5	77.5
50	75.4	77.0	77.5	77.5
70	75.4	77.0	77.5	77.5
100	77.0	78.0	79.0	83.0
150	77.0	78.0	79.0	83.0
200	82.0	82.5	85.0	86.0
250	82.0	82.5	85.0	86.0
300	82.0	82.5	85.0	86.0
350	83.0	83.0	86.0	86.0
400	83.0	83.0	86.0	86.0
500	86.0	87.0	89.0	90.0
550	86.0	87.0	89.0	90.0
600	86.0	87.0	89.0	90.0
1200	84.5	85.5	86.0	86.5
1600	84.5	85.5	86.0	86.5

5.12 PUMP SELECTION AND PERFORMANCE DATA

In table 508 are listed the actual delivery Q_{eff} and required power P_{mec} for each pump size at different speeds and pressures.

The data refer to a mineral oil ISO46 (Kinematic viscosity 46 cSt at 40°C).

The rated power for the the drive motor should be 20% higher than the required power P_{mec} .

For different viscosities please ask the performances (delivery and power) to our Technical department.

As a general rule the flow rate is approximately proportional to the speed.

A lower viscosity may lead to a loss of the net delivery and a higher viscosity may lead to an increase of the net delivery.

When dimensioning please consider the maximum viscosity, usually at the start-up phase.

Pump selection, delivery and required power at different speeds:

- 1) Given the project delivery Q_{pro} [L/min] and speed n_{pro} [1/min] calculate the project displacement V_{pro} [cm³/rev]:

$$V_{\text{pro}} = 1000 \times Q_{\text{pro}} / n_{\text{pro}}$$

- 2) Select the Pump Type with the geometrical displacement V_{geo} closer to V_{pro} .

- 3) Read from the Performance Table the delivery at 1450 1/min and at the given pressure p:

$$Q_{1450, p} \text{ [L/min]}$$

- 4) Calculate the actual delivery Q [L/min] at n_{pro} and p:

$$Q = Q_{1450, p} + V_{\text{geo}} \times (n_{\text{pro}} - 1450) / 1000$$

- 5) Read from the Performance Table the required power and actual delivery of the selected Pump Type at the closer speed n_x to n_{pro} and at p:

$$P_{n_x, p} \text{ [kW]}, Q_{n_x, p} \text{ [L/min]}$$

- 6) Calculate the actual required power P at n_{pro} and p [kW]:

$$P = P_{n_x, p} \times Q / Q_{n_x, p}$$

Tab. 508 - Performance data at 690, 830, 950, 1150, 1450, 1750 1/min and 46 cSt

PUMP SIZE (B, BC, MBM, MBMC)	Geometrical displacement V_{geo} [cm ³ /rev]	Pressure p [bar]	Speed n [1/min]											
			690		830		950		1150		1450		1750	
			Q_{eff} [L/min]	P_{mec} [kW]	Q_{eff} [L/min]	P_{mec} [kW]	Q_{eff} [L/min]	P_{mec} [kW]	Q_{eff} [L/min]	P_{mec} [kW]	Q_{eff} [L/min]	P_{mec} [kW]	Q_{eff} [L/min]	P_{mec} [kW]
5	4.6	2	3.0	0.04	3.6	0.05	4.2	0.06	5.0	0.08	6.4	0.10	7.7	0.13
		5	2.8	0.10	3.4	0.12	3.9	0.14	4.8	0.17	6.1	0.21	7.4	0.2
		10	2.5	0.19	3.0	0.22	3.5	0.26	4.3	0.31	5.6	0.38	6.8	0.5
		12	2.3	0.22	2.9	0.27	3.3	0.31	4.1	0.37	5.3	0.45	6.6	0.5
10	9.1	2	6.0	0.05	7.3	0.06	8.3	0.08	10.1	0.10	12.8	0.13	15.5	0.2
		5	5.6	0.13	6.9	0.15	7.9	0.18	9.6	0.2	12.3	0.3	14.9	0.3
		10	5.0	0.25	6.2	0.30	7.1	0.34	8.8	0.4	11.3	0.5	13.9	0.6
		12	4.8	0.30	5.9	0.36	6.8	0.41	8.5	0.5	11.0	0.6	13.5	0.7
15	13.6	2	9.0	0.08	10.8	0.10	12.4	0.12	15.1	0.2	19.1	0.2	23.1	0.3
		5	8.3	0.19	10.1	0.23	11.6	0.27	14.2	0.3	18.1	0.4	22.0	0.5
		10	7.1	0.37	8.8	0.45	10.2	0.52	12.7	0.6	16.4	0.8	20.2	1.0
		12	6.7	0.44	8.3	0.54	9.7	0.62	12.1	0.7	15.7	0.9	19.5	1.1
25	18.2	2	12.0	0.08	14.4	0.11	16.6	0.13	20.1	0.2	25.5	0.2	30.9	0.3
		5	11.1	0.2	13.4	0.2	15.5	0.3	19.0	0.4	24.2	0.5	29.5	0.6
		10	9.6	0.4	11.8	0.5	13.7	0.6	17.0	0.7	22.0	0.9	27.2	1.0
		12	9.0	0.5	11.1	0.6	13.0	0.7	16.2	0.8	21.2	1.0	26.2	1.2
40	28.1	2	18.4	0.2	22.2	0.2	25.5	0.2	31.0	0.3	39.3	0.4	47.6	0.5
		5	17.0	0.4	20.6	0.5	23.8	0.5	29.1	0.7	37.1	0.9	45.2	1.1
		10	14.6	0.8	18.0	0.9	20.9	1.1	25.9	1.3	33.5	1.7	41.3	2.0
		12	13.6	0.9	16.9	1.1	19.7	1.3	24.6	1.6	32.1	2.0	39.8	2.4
50	41.2	2	27.7	0.3	33.4	0.4	38.4	0.4	46.5	0.6	58.7	0.8	70.9	1.1
		5	26.7	0.5	32.5	0.6	37.5	0.7	45.5	0.9	57.5	1.3	69.5	1.7
		10	25.1	0.8	30.9	0.9	36.0	1.1	43.8	1.5	55.5	2.1	67.3	2.7
		12	24.5	0.9	30.3	1.1	35.4	1.2	43.1	1.8	54.7	2.4	66.4	3.0
70	50.3	2	33.6	0.3	40.8	0.4	46.8	0.5	56.7	0.7	71.5	0.9	86.4	1.2
		5	31.9	0.5	39.4	0.8	45.2	0.9	54.9	1.2	69.4	1.6	83.9	2.0
		10	29.2	0.9	37.2	1.3	42.7	1.6	51.9	2.0	65.8	2.7	79.8	3.4
		12	28.1	1.0	36.2	1.6	41.6	1.9	50.7	2.4	64.4	3.2	78.2	4.0
100	81.4	2	55.2	0.4	66.7	0.5	76.5	0.5	92.9	0.7	117.0	1.0	141.3	1.2
		5	53.8	0.7	65.3	0.9	75.2	1.0	91.9	1.2	115.6	1.7	139.7	2.2
		10	51.5	1.3	63.1	1.5	73.2	1.8	90.2	2.1	113.3	3.0	136.9	3.8
		12	50.6	1.5	62.2	1.8	72.4	2.1	89.5	2.5	112.3	3.5	135.8	4.4
150	117.5	2	79.2	0.6	95.7	0.7	110.0	0.9	133.3	1.1	168.1	1.6	203.0	2.0
		5	76.4	1.0	92.9	1.3	107.6	1.6	130.4	2.1	164.7	2.8	198.9	3.5
		10	71.7	1.8	88.3	2.2	103.6	2.9	125.7	3.6	158.9	4.8	192.2	6.1
		12	69.9	2.1	86.5	2.6	102.0	3.4	123.8	4.2	156.6	5.6	189.5	7.1
200	149.5	2	100.1	0.7	123.3	0.9	139.0	1.1	169.1	1.5	213.4	2.1		
		5	95.4	1.3	123.8	1.6	134.4	1.9	164.8	2.5	208.3	3.4		
		10	87.7	2.3	124.0	2.8	126.8	3.2	157.7	4.2	199.9	5.6		
		12	84.6	2.7	124.0	3.3	123.8	3.8	154.8	4.8	196.5	6.5		

Different viscosities, working pressure, rotational speed and ambient conditions can change performance data shown in the table.

Tab. 508 - Performance data at 690, 830, 950, 1150, 1450, 1750 1/min and 46 cSt

PUMP SIZE (B, BC, MBM, MBMC)	Geometrical displacement V_{geo} [cm ³ /rev]	Pressure p [bar]	Speed n [1/min]											
			690		830		950		1150		1450		1750	
			Q_{eff} [L/min]	P_{mec} [kW]	Q_{eff} [L/min]	P_{mec} [kW]	Q_{eff} [L/min]	P_{mec} [kW]	Q_{eff} [L/min]	P_{mec} [kW]	Q_{eff} [L/min]	P_{mec} [kW]	Q_{eff} [L/min]	P_{mec} [kW]
250	185.4	2	124.5	0.9	150.5	1.2	173.1	1.5	209.8	1.9	264.7	2.7		
		5	119.3	1.7	145.5	2.1	168.6	2.5	204.6	3.2	258.6	4.4		
		10	110.7	3.0	137.1	3.7	161.1	4.2	195.9	5.4	248.3	7.3		
		12	107.3	3.6	133.7	4.3	158.1	4.9	192.4	6.2	244.2	8.4		
300	221.3	2	146.6	1.1	177.2	1.4	203.6	1.7	247.7	2.2	314.6	3.1		
		5	137.5	2.0	167.5	2.5	193.6	3.0	237.4	3.7	305.2	5.1		
		10	122.3	3.6	151.4	4.4	176.9	5.1	220.3	6.3	289.5	8.5		
		12	116.2	4.2	144.9	5.2	170.2	6.0	213.4	7.3	283.3	9.8		
350	257.2	2	169.6	1.1	204.9	1.4	238.1	1.7	288.5	2.2	364.3	2.9		
		5	157.7	2.2	192.1	2.6	228.7	3.1	277.7	3.9	351.3	5.3		
		10	137.9	4.1	170.8	4.7	213.1	5.5	259.5	6.9	329.7	9.2		
		12	130.0	4.8	162.2	5.5	206.8	6.4	252.3	8.1	321.0	10.8		
400	299.1	2	198.5	1.3	239.8	1.6	275.2	1.9	335.2	2.5	423.2	3.4		
		5	186.9	2.6	227.1	3.2	261.9	3.6	322.1	4.5	407.5	6.1		
		10	167.4	4.9	206.0	5.7	239.8	6.3	300.2	7.9	381.4	10.6		
		12	159.6	5.8	197.6	6.7	230.9	7.4	291.5	9.3	371.0	12.4		
500	369.6	2	248.7	1.8	302.4	2.3	346.3	2.7	419.4	3.5	529.1	4.8		
		5	238.8	3.3	295.5	4.3	338.5	5.1	410.3	6.5	518.2	8.7		
		10	222.4	5.8	284.0	7.6	325.6	9.0	395.2	11.3	500.0	15.1		
		12	215.8	6.8	279.4	9.0	320.5	10.5	389.2	13.3	492.7	17.7		
550	407.9	2	271.1	1.9	328.6	1.4	380.1	2.9	460.3	3.7	580.8	5.0		
		5	255.6	3.6	313.8	1.2	368.9	5.4	447.2	6.8	564.9	9.2		
		10	229.8	6.5	289.1	1.1	350.4	9.6	425.5	12.1	538.4	16.0		
		12	219.4	7.7	279.2	1.1	343.0	11.3	416.7	14.2	527.8	18.8		
600	446.1	2	299.8	1.8	361.1	2.3	413.8	2.7	501.6	3.4	633.5	4.7		
		5	287.9	4.0	347.6	4.9	398.9	5.6	484.6	7.0	613.7	9.0		
		10	268.1	7.6	325.0	9.2	374.0	10.5	456.3	12.8	580.8	16.2		
		12	260.2	9.1	315.9	10.9	364.1	12.5	445.0	15.2	567.6	19.1		
1200	885.5	2	595.4	6.3	720.2	8.2								
		5	572.2	11.5	698.1	14.1								
		10	533.4	20.0	661.2	24.0								
		12	517.9	23.4	646.5	28.0								
1600	1201.7	2	809.0	7.5	975.8	9.7								
		5	778.9	14.9	943.4	18.4								
		10	728.6	27.2	889.3	32.9								
		12	708.5	32.1	867.7	38.7								

Different viscosities, working pressure, rotational speed and ambient conditions can change performance data shown in the table.

5.13 OVERALL DIMENSIONS AND WEIGHTS

5.13.1 B

Fig. 507 - B5 to B40 dimensional drawing

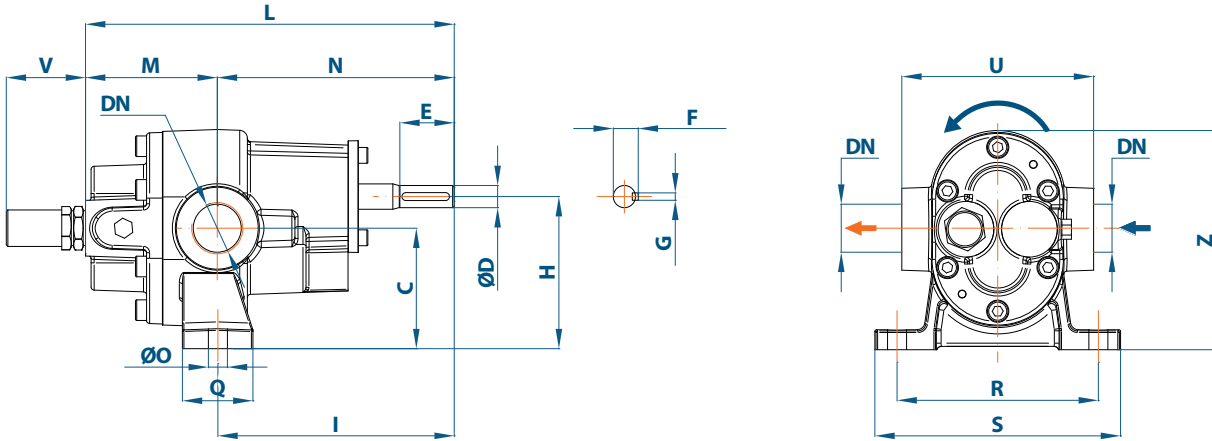

Tab. 509 - B5 to B40 overall dimensions and weights

PUMP SIZE (B)	DN ISO 228-1	C	D	E	F	G	H	I	L	M	N	O	Q	R	S	U	V	Z	Weight [kg]
5	G 1/2"	64	12	28	13.5	4	80	98.5	162	64	98	10.5	36	105	130	90	50	117	3.4
10	G 1/2"	64	12	28	13.5	4	80	98.5	172	74	98	10.5	36	105	130	90	50	117	3.8
15	G 3/4"	64	12	28	13.5	4	80	114.5	182.5	68	114.5	10.5	41.5	105	130	95	50	117	4.1
25	G 3/4"	64	12	30	13.5	4	80	114.5	192.5	78	114.5	10.5	41.5	105	130	95	50	117	4.5
40	G 1"	76	14	35	16	5	96	149.5	232.5	83	149.5	10.5	44.5	127	155	121	50	139	7.2

Dimensions in mm; tolerances allowed.

Fig. 508 - B50 to B70 dimensional drawing

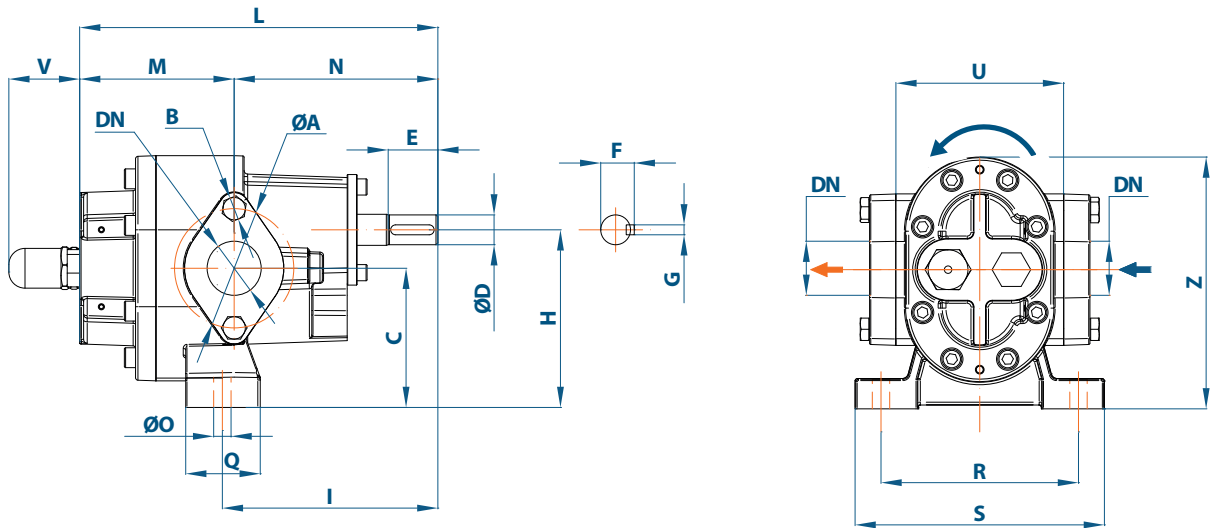

Tab. 510 - B50 to B70 overall dimensions and weights

PUMP SIZE (B)	DN ISO 228-1	A	B	C	D	E	F	G	H	I	L	M	N	O	Q	R	S	U	V	Z	Weight [kg]
	50	G1"1/2	75	N°2-M10	91.5	14	35	16	5	114	156	236	87	149	12	53	127	157	98	50	
70	G1"1/2	75	N°2-M10	91.5	14	35	16	5	114	156	246	90	156	12	53	127	157	98	50	162	10.7

Dimensions in mm; tolerances allowed.

Fig. 509 - B100 to B150 dimensional drawing

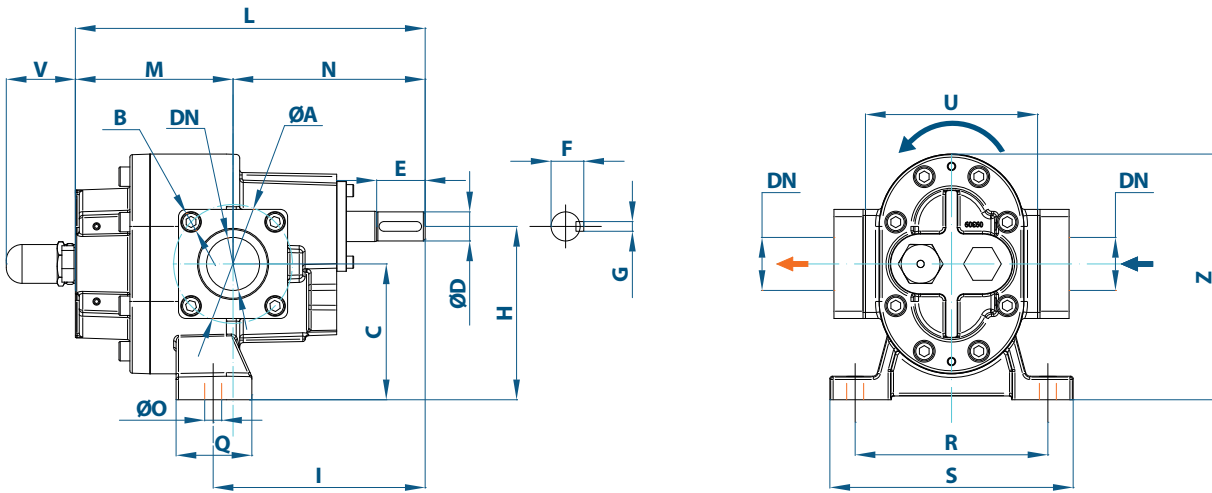

Tab. 511 - B100 to B150 overall dimensions and weights

PUMP SIZE (B)	DN	A	B	C	D	E	F	G	H	I	L	M	N	O	Q	R	S	U	V	Z	Weight [kg]
	ISO 228-1																				
100	G 2"	98	N*4-M10	111	24	40	27	8	142	175	268.5	110	158.5	14	62.5	159	201	142	57	203	21.5
150	G 2"	98	N*4-M10	111	24	40	27	8	142	175	288.5	130	158.5	14	62.5	159	201	142	57	203	24

Dimensions in mm; tolerances allowed.

Fig. 510 - B200 to B600 dimensional drawing

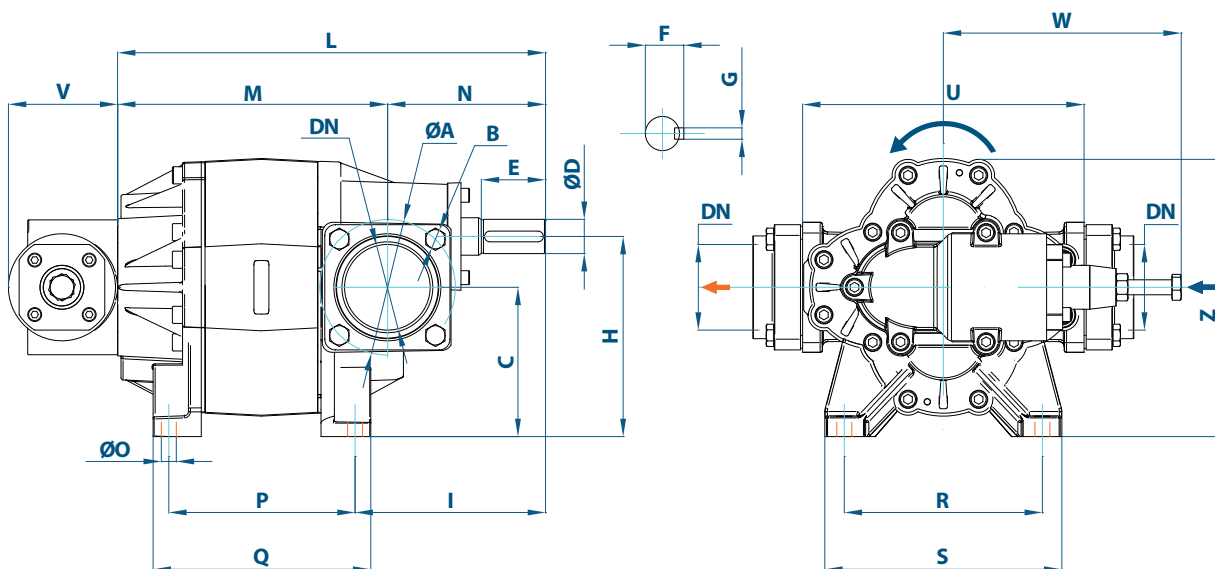

Tab. 512 - B200 to B600 overall dimensions and weights

PUMP SIZE (B)	DN ISO 228-1	Dimensions																				Weight [kg]	
		A	B	C	D	E	F	G	H	I	L	M	N	O	P	Q	R	S	U	V	W		Z
200	G 2"1/2	115	N°4-M12	106	28	60	31	8	142	168	323	178	145	13	118	151	139	171	210	71	210	200	31.4
250	G 2"1/2	115	N°4-M12	106	28	60	31	8	142	168	335	190	145	13	130	163	139	171	210	71	210	200	33
300	G 2"1/2	115	N°4-M12	106	28	60	31	8	142	168	347	202	145	13	142	175	139	171	210	71	210	200	35
350	G 2"1/2	115	N°4-M12	106	28	60	31	8	142	168	359	214	145	13	154	187	139	171	210	71	210	200	36
400	G 2"1/2	115	N°4-M12	106	28	60	31	8	142	168	373	228	145	13	168	201	139	171	210	71	210	200	38
500	G 3"	127	N°4-M12	139.5	32	60	35	10	187	181	382	234	148	13	151	169	185	222	263	102	222	260	60
550	G 3"	127	N°4-M12	139.5	32	60	35	10	187	181	391	243	148	13	160	178	185	222	263	102	222	260	61
600	G 3"	127	N°4-M12	139.5	32	60	35	10	187	181	400	252	148	13	169	187	185	222	263	102	222	260	63

Dimensions in mm; tolerances allowed.

Fig. 511 - B1200 to B1600 dimensional drawing

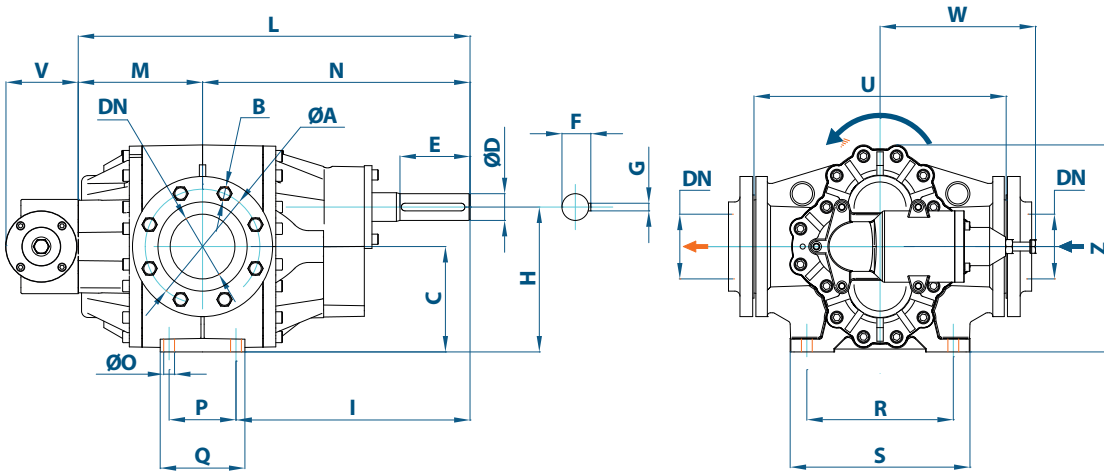

Tab. 513 - B1200 to B1600 overall dimensions and weights

PUMP SIZE (B)	DN UNI 2254	A	B	C	D	E	F	G	H	I	L	M	N	O	P	Q	R	S	U	V	W	Z	Weight [kg]
		1200	G 4"	180	N°8-M16	165.5	42	110	45	12	227.5	342.5	565	170	395	17	105	133	230	282	396	113.5	
1600	G 4"	180	N°8-M16	165.5	42	110	45	12	227.5	367.5	615	195	420	17	105	133	230	282	396	113.5	244	325	158

Dimensions in mm; tolerances allowed.

5.13.2 BC

Fig. 512 - BC10 to BC25 dimensional drawing

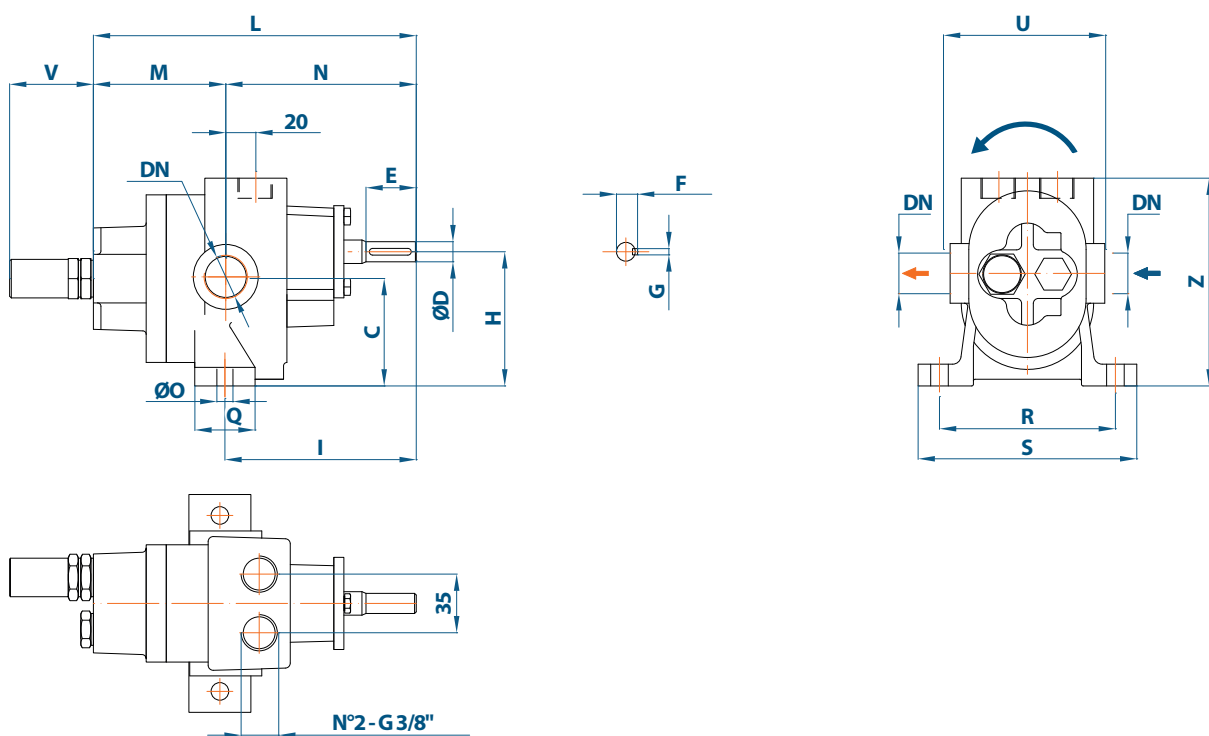

Tab. 514 - BC10 to BC25 overall dimensions and weights

PUMP SIZE (BC)	DN ISO 228-1	C	D	E	F	G	H	I	L	M	N	O	Q	R	S	U	V	Z	Weight [kg]
10	G 1/2"	64	12	28	13.5	4	80	98.5	172	74	98	10.5	36	105	130	90	50	117	3.8
15	G 3/4"	64	12	28	13.5	4	80	114.5	182.5	68	114.5	10.5	41.5	105	130	95	50	117	4.1
25	G 3/4"	64	12	30	13.5	4	80	114.5	192.5	78	114.5	10.5	41.5	105	130	95	50	117	4.5

Dimensions in mm; tolerances allowed.

Fig. 513 - BC50 to BC70 dimensional drawing

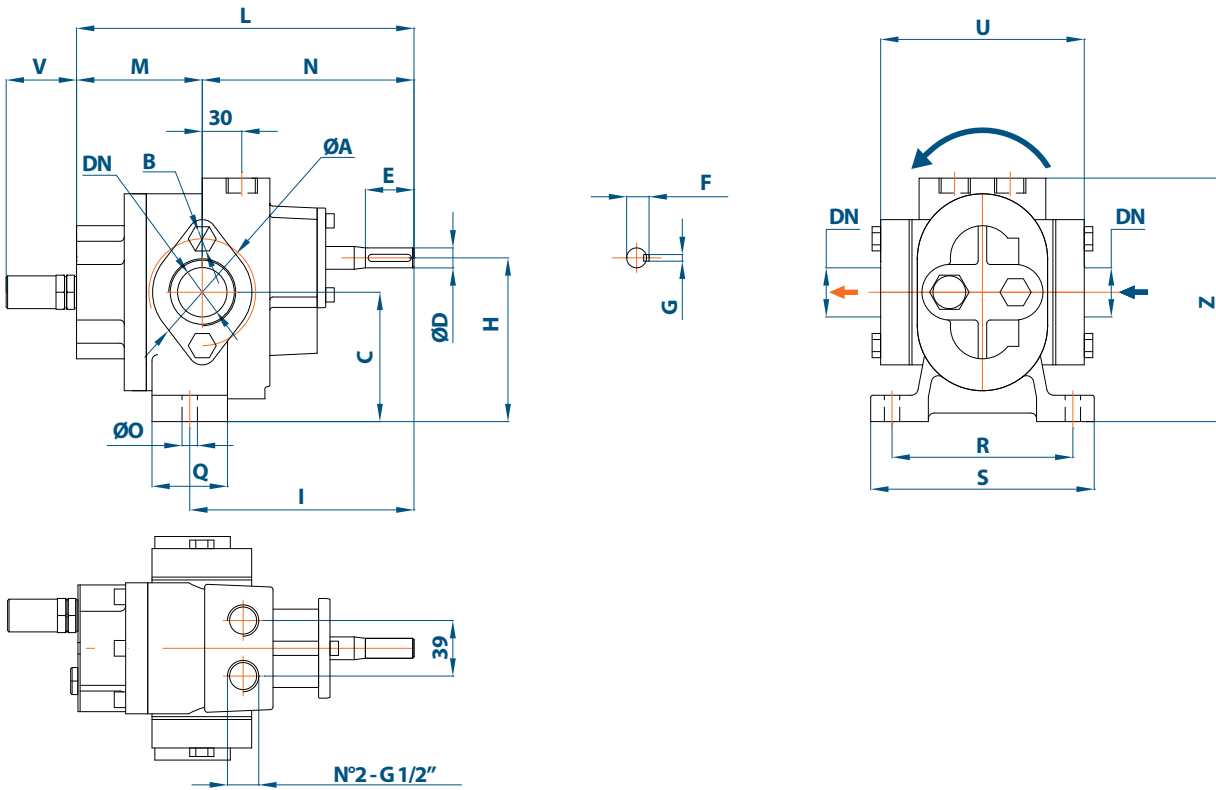

Tab. 515 - BC50 to BC70 overall dimensions and weights

PUMP SIZE (BC)	DN ISO 228-1	A	B	C	D	E	F	G	H	I	L	M	N	O	Q	R	S	U	V	Z	Weight [kg]
50	G 1"1/2	75	N°2-M10	91.5	14	35	16	5	114	156	236	87	149	12	53	127	157	98	50	162	9.8
70	G 1"1/2	75	N°2-M10	91.5	14	35	16	5	114	156	246	90	156	12	53	127	157	98	50	162	10.7

Dimensions in mm; tolerances allowed.

Fig. 514 - BC100 to BC150 dimensional drawing

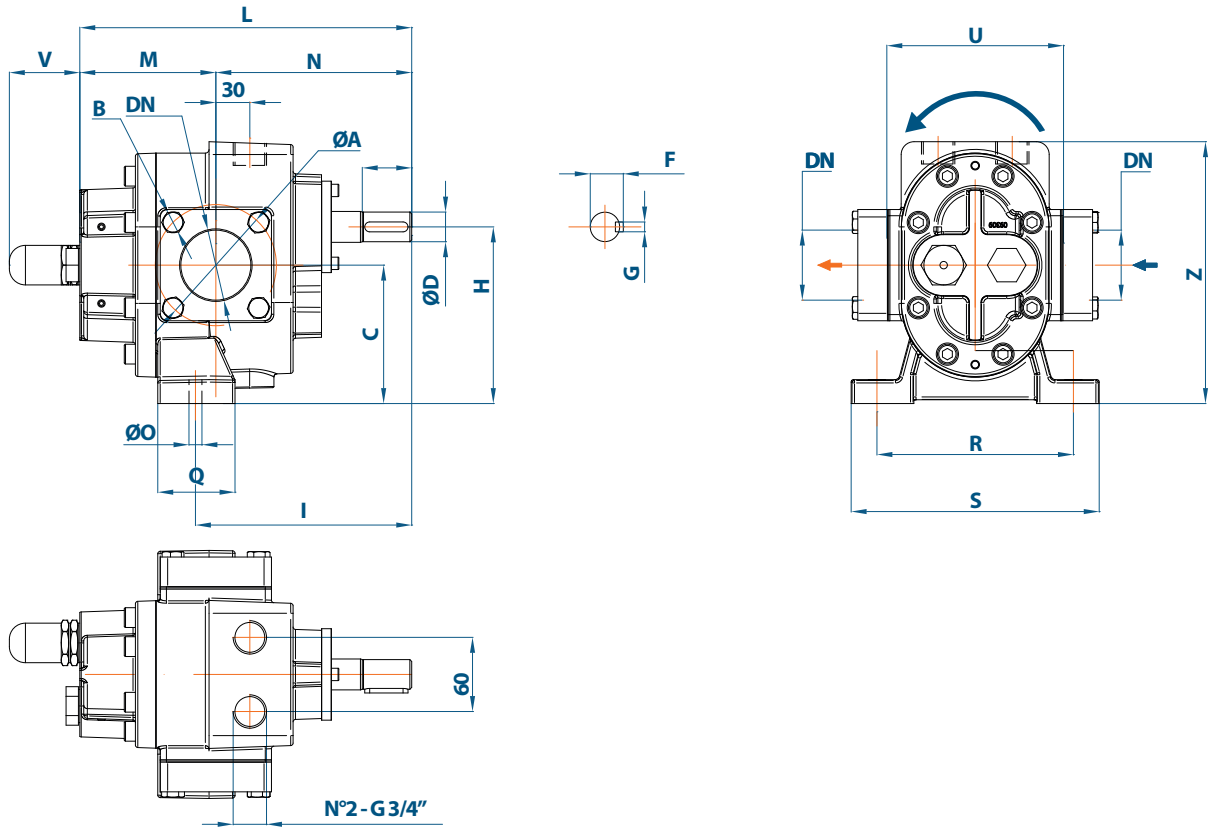

Tab. 516 - BC100 to BC150 overall dimensions and weights

PUMP SIZE (BC)	DN ISO 228-1	A	B	C	D	E	F	G	H	I	L	M	N	O	Q	R	S	U	V	Z	Weight [kg]
		100	G 2"	98	N°4-M10	111	24	40	27	8	142	175	268.5	110	158.5	14	62.5	159	201	142	
150	G 2"	98	N°4-M10	111	24	40	27	8	142	175	288.5	130	158.5	14	62.5	159	201	142	57	203	24

Dimensions in mm; tolerances allowed.

Fig. 515 - BC200 to BC400 dimensional drawing

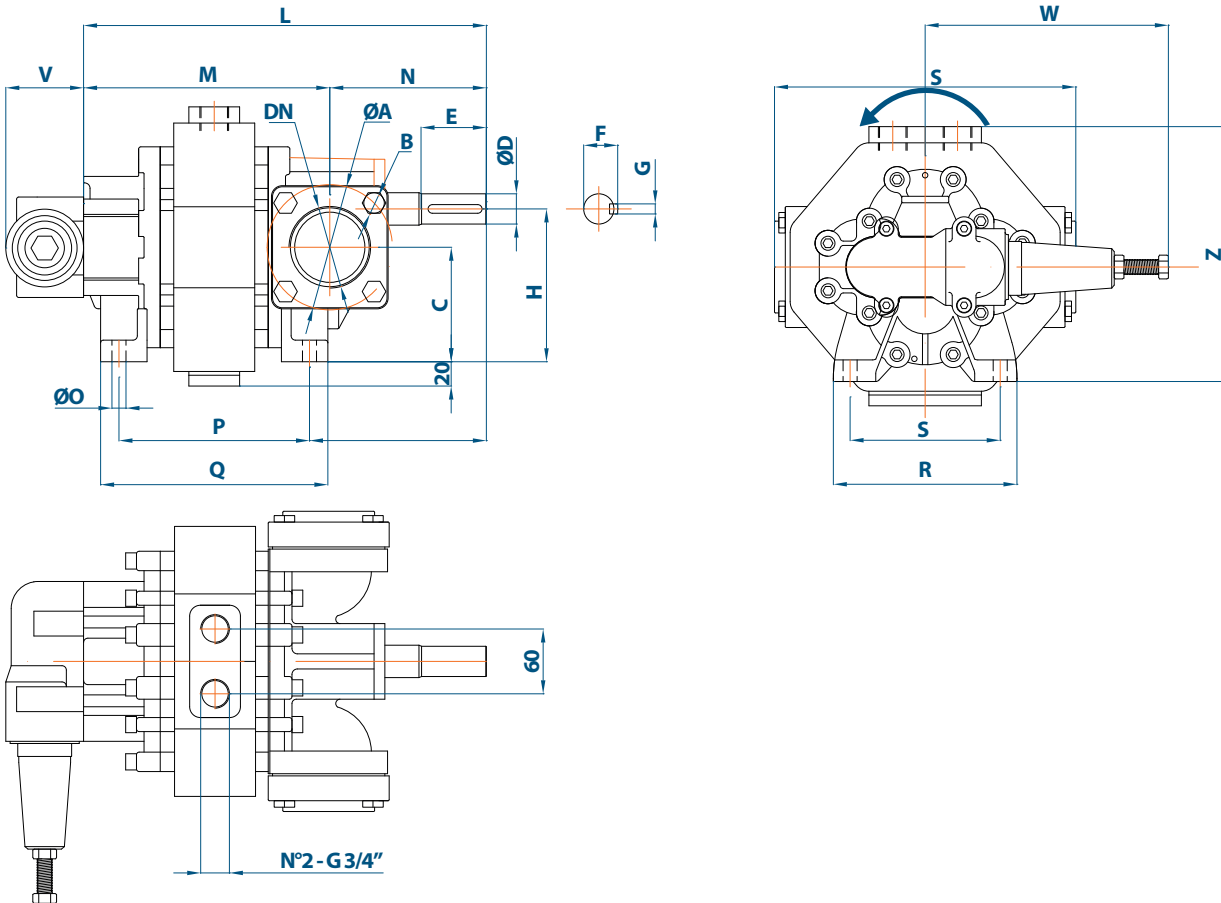

Tab. 517 - BC200 to BC400 overall dimensions and weights

PUMP SIZE (BC)	DN ISO 228-1																					Weight [kg]	
		A	B	C	D	E	F	G	H	I	L	M	N	O	P	Q	R	S	U	V	W		Z
200	G 2"1/2	115	N°4-M12	106	28	60	31	8	142	168	323	178	145	13	118	151	139	171	210	71	210	200	31,4
250	G 2"1/2	115	N°4-M12	106	28	60	31	8	142	168	335	190	145	13	130	163	139	171	210	71	210	200	33
300	G 2"1/2	115	N°4-M12	106	28	60	31	8	142	168	347	202	145	13	142	175	139	171	210	71	210	200	35
350	G 2"1/2	115	N°4-M12	106	28	60	31	8	142	168	359	214	145	13	154	187	139	171	210	71	210	200	36
400	G 2"1/2	115	N°4-M12	106	28	60	31	8	142	168	373	228	145	13	168	201	139	171	210	71	210	200	38

Dimensions in mm; tolerances allowed.

5.13.3 MBM, MBMC

Fig. 516 - MBM5-40, MBMC10-25 dimensional drawing

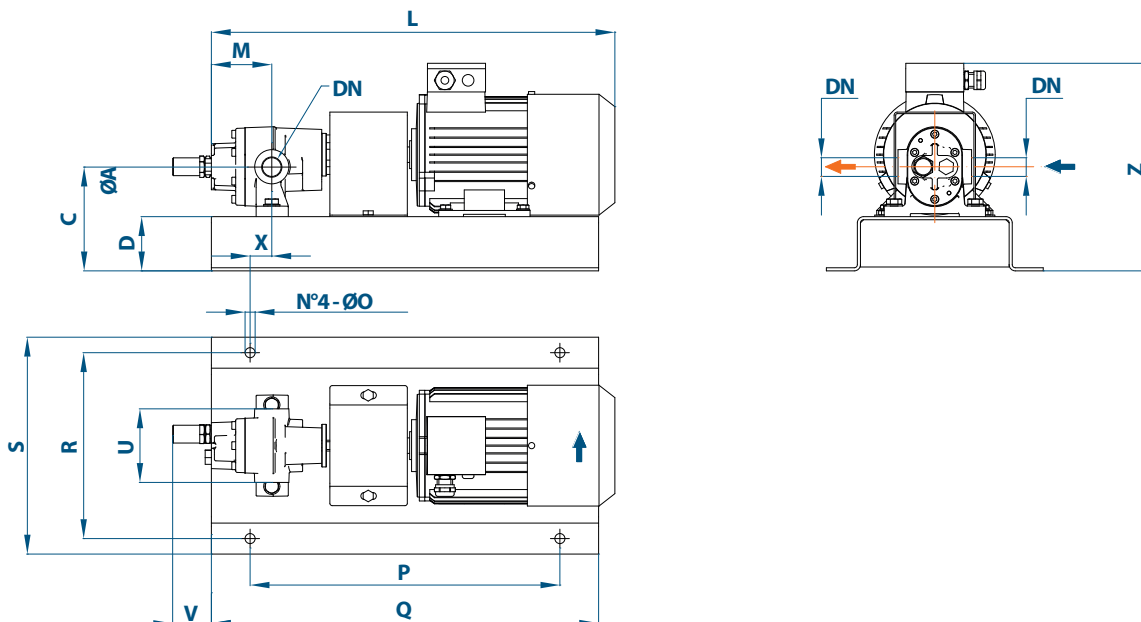

Tab. 518 - MBM5 to MBM40, MBMC10 to MBMC25 overall dimensions and weights

PUMP SIZE (MBM) (MBMC)		with IEC electric motor		DN ISO 228-1	C	D	L (*)	M	O	P	Q	R	S	U	V	X	Z (*)	Weight [kg]
		Frame size	IM															
5		71	B3	G 1/2"	134	70	423	64	13	300	400	240	280	90	50	14	261	16
		80	B3	G 1/2"	134	70	484	64	13	400	500	240	280	90	50	14	270	23
		90	B3	G 1/2"	144	70	534	64	13	400	500	240	280	90	50	14	308	33
10	10	71	B3	G 1/2"	134	70	433	74	13	300	400	240	280	90	50	24	261	16
		80	B3	G 1/2"	134	70	494	74	13	400	500	240	280	90	50	24	270	23
		90	B3	G 1/2"	144	70	544	74	13	400	500	240	280	90	50	24	308	33
15	15	71	B3	G 3/4"	134	70	443.5	68	13	300	400	240	280	95	50	18	261	17
		80	B3	G 3/4"	134	70	504.5	68	13	400	500	240	280	95	50	18	270	23
		90	B3	G 3/4"	144	70	554.5	68	13	400	500	240	280	95	50	18	308	33
25	25	80	B3	G 3/4"	134	70	514.5	78	13	400	500	240	280	95	50	28	270	24
		90	B3	G 3/4"	144	70	564.5	78	13	400	500	240	280	95	50	28	308	34
40		80	B3	G 1"	146	70	554.5	83	13	400	500	240	280	121	50	33	286	26
		90	B3	G 1"	146	70	604.5	83	13	500	600	290	330	121	50	33	314	36
		100	B3	G 1"	150	70	667.5	83	13	500	600	290	330	121	50	33	327	50

Dimensions in mm; tolerances allowed; (*) = depends on the motor manufacturer

Fig. 517 - MBM50-70, MBMC50-70 dimensional drawing

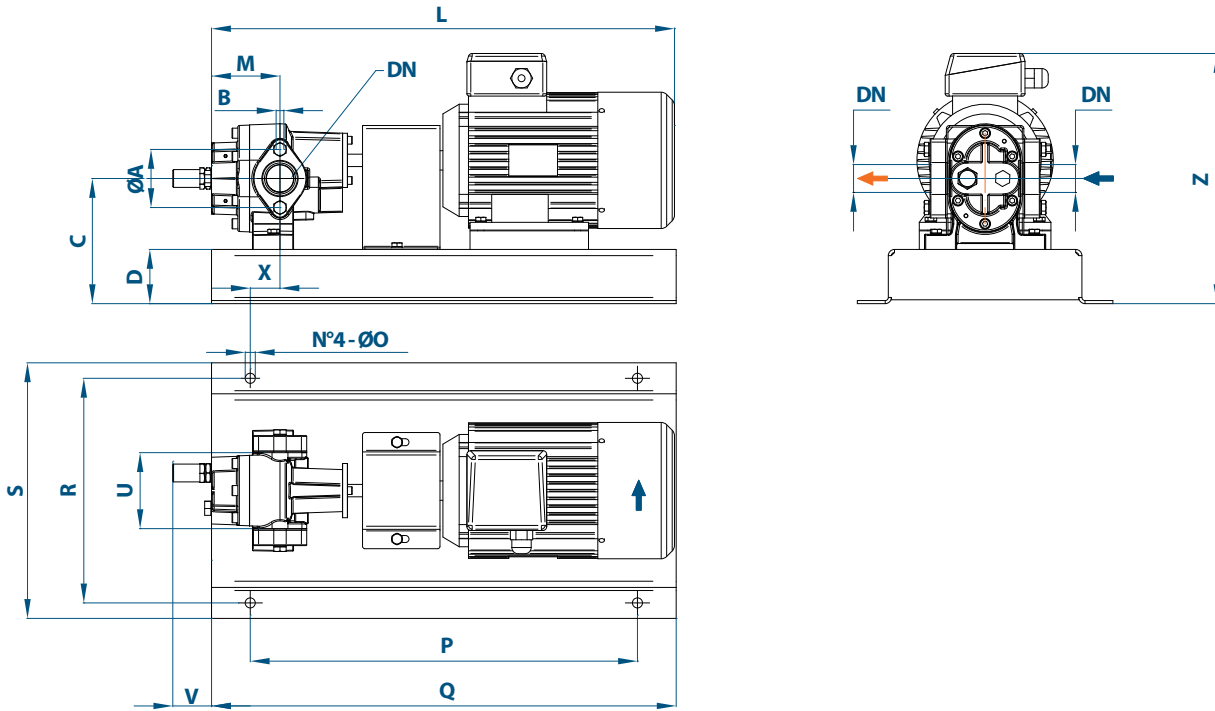

Tab. 519 - MBM50 to MBM70, MBMC50 to MBMC70 overall dimensions and weights

PUMP SIZE		with IEC electric motor		DN ISO 228-1	A	B	C	D	L (*)	M	O	P	Q	R	S	U	V	X	Z (*)	Weight [kg]
(MBM)	(MBMC)	Frame size	IM																	
50	50	90	B3	G1"1/2	75	N°2-M10	161.5	70	608	87	13	500	600	290	330	98	50	37	332	39
		100	B3	G1"1/2	75	N°2-M10	161.5	70	671	87	13	500	600	290	330	98	50	37	341	52
		112	B3	G1"1/2	75	N°2-M10	161.5	70	679	87	13	500	600	290	330	98	50	37	352	65
70	70	90	B3	G1"1/2	75	N°2-M10	161.5	70	618	90	13	500	600	290	330	98	50	40	332	40
		100	B3	G1"1/2	75	N°2-M10	161.5	70	681	90	13	500	600	290	330	98	50	40	341	53
		112	B3	G1"1/2	75	N°2-M10	161.5	70	689	90	13	500	600	290	330	98	50	40	352	65
		132	B3	G1"1/2	75	N°2-M10	179.5	70	778	90	13	550	650	340	380	98	50	40	399	97

Dimensions in mm; tolerances allowed; (*) = depends on the motor manufacturer

Fig. 518 - MBM100-150, MBMC100-150 dimensional drawing

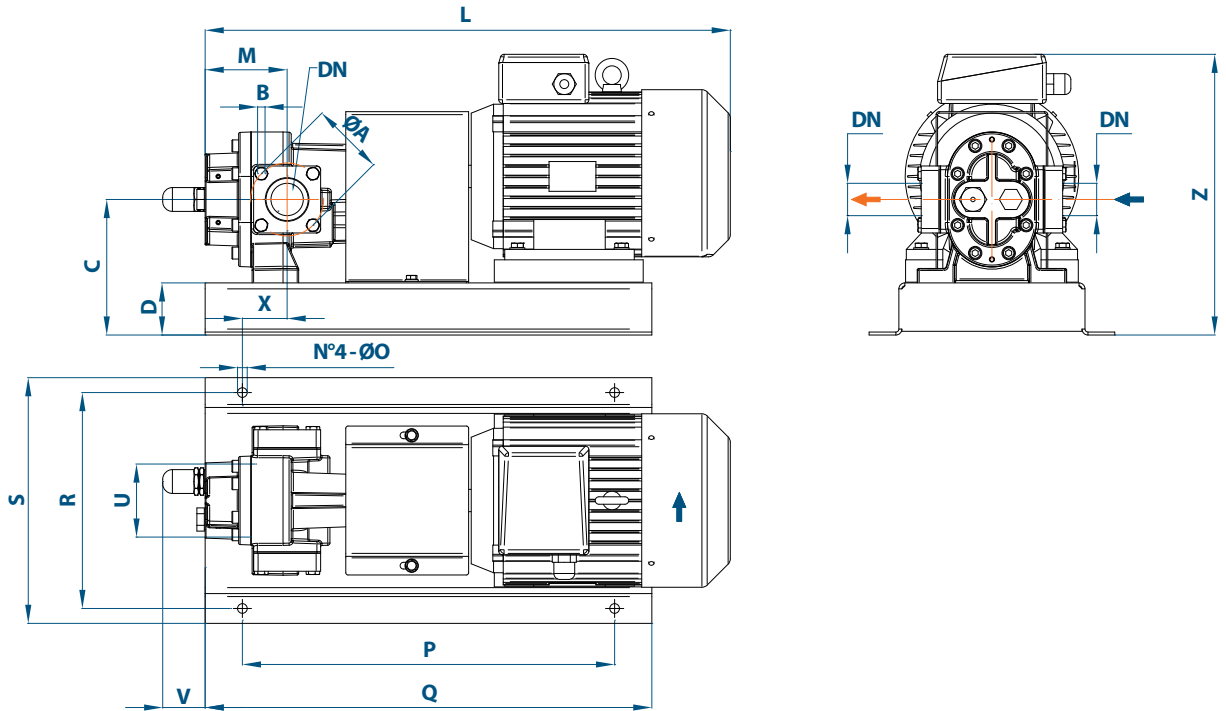

Tab. 520 - MBM100 to MBM150, MBMC100 to MBMC150 overall dimensions and weights

PUMP SIZE		with IEC electric motor		DN ISO 228-1	A	B	C	D	L (*)	M	O	P	Q	R	S	U	V	X	Z (*)	Weight [kg]
(MBM)	(MBMC)	Frame size	IM																	
100	100	90	B3	G 2"	98	N°4-M10	181	70	640.5	110	13	500	600	290	330	142	57	60	361	51
		100	B3	G 2"	98	N°4-M10	181	70	703.5	110	13	500	600	290	330	142	57	60	370	64
		112	B3	G 2"	98	N°4-M10	181	70	711.5	110	13	550	650	340	380	142	57	60	381	76
		132	B3	G 2"	98	N°4-M10	181	70	800.5	110	13	550	650	340	380	142	57	60	410	108
150	150	100	B3	G 2"	98	N°4-M10	181	70	723.5	130	13	500	600	290	330	142	57	80	370	66
		112	B3	G 2"	98	N°4-M10	181	70	731.5	130	13	550	650	340	380	142	57	80	381	79
		132	B3	G 2"	98	N°4-M10	181	70	820.5	130	13	700	800	400	440	142	57	80	410	110

Dimensions in mm; tolerances allowed; (*) = depends on the motor manufacturer

Fig. 519 - MBM200-600, MBMC200-400 dimensional drawing

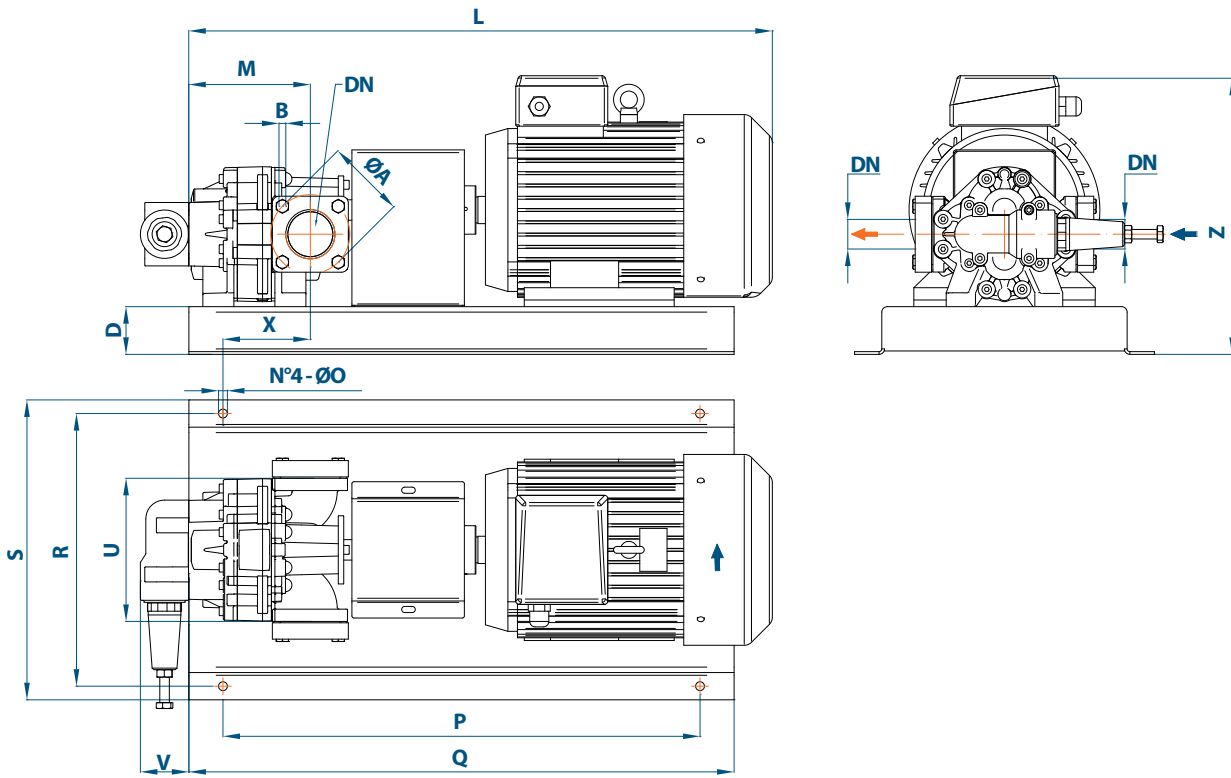

Tab. 521 – MBM200 to MBM600, MBMC200 to MBMC400 overall dimensions and weights

PUMP SIZE		with IEC electric motor		DN ISO 228-1	A	B	C	D	L (*)	M	O	P	Q	R	S	U	V	X	Z (*)	Weight [kg]
(MBM)	(MBMC)	Frame size	IM																	
200	200	112	B3	G 2"1/2	115	N°4-M12	176	70	766	178	13	700	800	400	440	210	71	128	380	86
		132	B3	G 2"1/2	115	N°4-M12	176	70	855	178	13	700	800	400	440	210	71	128	409	118
		160	B3	G 2"1/2	115	N°4-M12	194	70	990	178	13	900	1000	400	440	210	71	128	453	209
250	250	112	B3	G 2"1/2	115	N°4-M12	176	70	778	190	13	700	800	400	440	210	71	140	380	88
		132	B3	G 2"1/2	115	N°4-M12	176	70	867	190	13	700	800	400	440	210	71	140	409	119
		160	B3	G 2"1/2	115	N°4-M12	194	70	1002	190	13	900	1000	400	440	210	71	140	453	211
300	300	132	B3	G 2"1/2	115	N°4-M12	176	70	879	202	13	700	800	400	440	210	71	152	409	121
		160	B3	G 2"1/2	115	N°4-M12	194	70	1014	202	13	900	1000	400	440	210	71	152	453	213
350	350	132	B3	G 2"1/2	115	N°4-M12	176	70	891	214	13	700	800	400	440	210	71	164	409	122
		160	B3	G 2"1/2	115	N°4-M12	194	70	1026	214	13	900	1000	400	440	210	71	164	453	214
400	400	132	B3	G 2"1/2	115	N°4-M12	176	70	905	228	13	700	800	400	440	210	71	178	409	124
		160	B3	G 2"1/2	115	N°4-M12	194	70	1040	228	13	900	1000	400	440	210	71	178	453	216
		180	B3	G 2"1/2	115	N°4-M12	214	70	1122	228	13	900	1000	400	440	210	71	178	484	263
500		132	B3	G 3"	127	N°4-M12	209.5	70	914	234	13	700	800	400	440	263	102	184	454	146
		160	B3	G 3"	127	N°4-M12	209.5	70	1049	234	13	900	1000	400	440	263	102	184	480	238
		180	B3	G 3"	127	N°4-M12	209.5	70	1131	234	13	900	1000	400	440	263	102	184	491	285
550		160	B3	G 3"	127	N°4-M12	209.5	70	1058	243	13	900	1000	400	440	263	102	193	480	239
		180	B3	G 3"	127	N°4-M12	209.5	70	1140	243	13	900	1000	400	440	263	102	193	491	286
600		160	B3	G 3"	127	N°4-M12	209.5	70	1067	252	13	900	1000	400	440	263	102	202	480	241
		180	B3	G 3"	127	N°4-M12	209.5	70	1149	252	13	900	1000	400	440	263	102	202	491	288

Dimensions in mm; tolerances allowed; (*) = depends on the motor manufacturer

Fig. 520 - MBM1200-1600 dimensional drawing

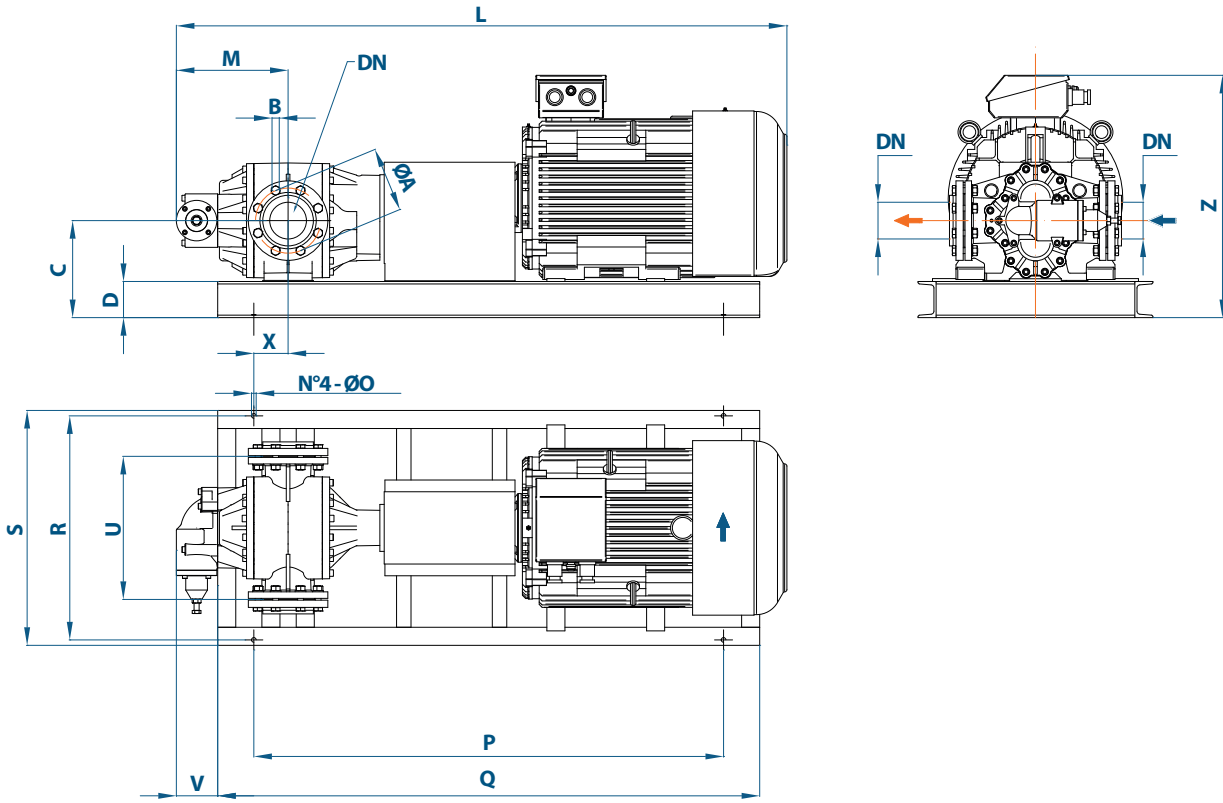

Tab. 522 - MBM1200 to MBM1600 overall dimensions and weights

PUMP SIZE (MBM)	with IEC electric motor		DN	A	B	C	D	L (*)	M	O	P	Q	R	S	U	V	X	Z (*)	Weight [kg]
	Frame size	IM	UNI 2254																
1200	225	B3	G 4"	180	N°8-M16	235.5	70	1525	234	13	1400	1500	620	650	396	114	184	643	608
1600	225	B3	G 4"	180	N°8-M16	235.5	70	1575	243	13	1400	1500	620	650	396	114	193	643	633

Dimensions in mm; tolerances allowed; (*) = depend on the motor maker.

5.14 SPARE PARTS

Fig. 521 - B3-40; BC10-25

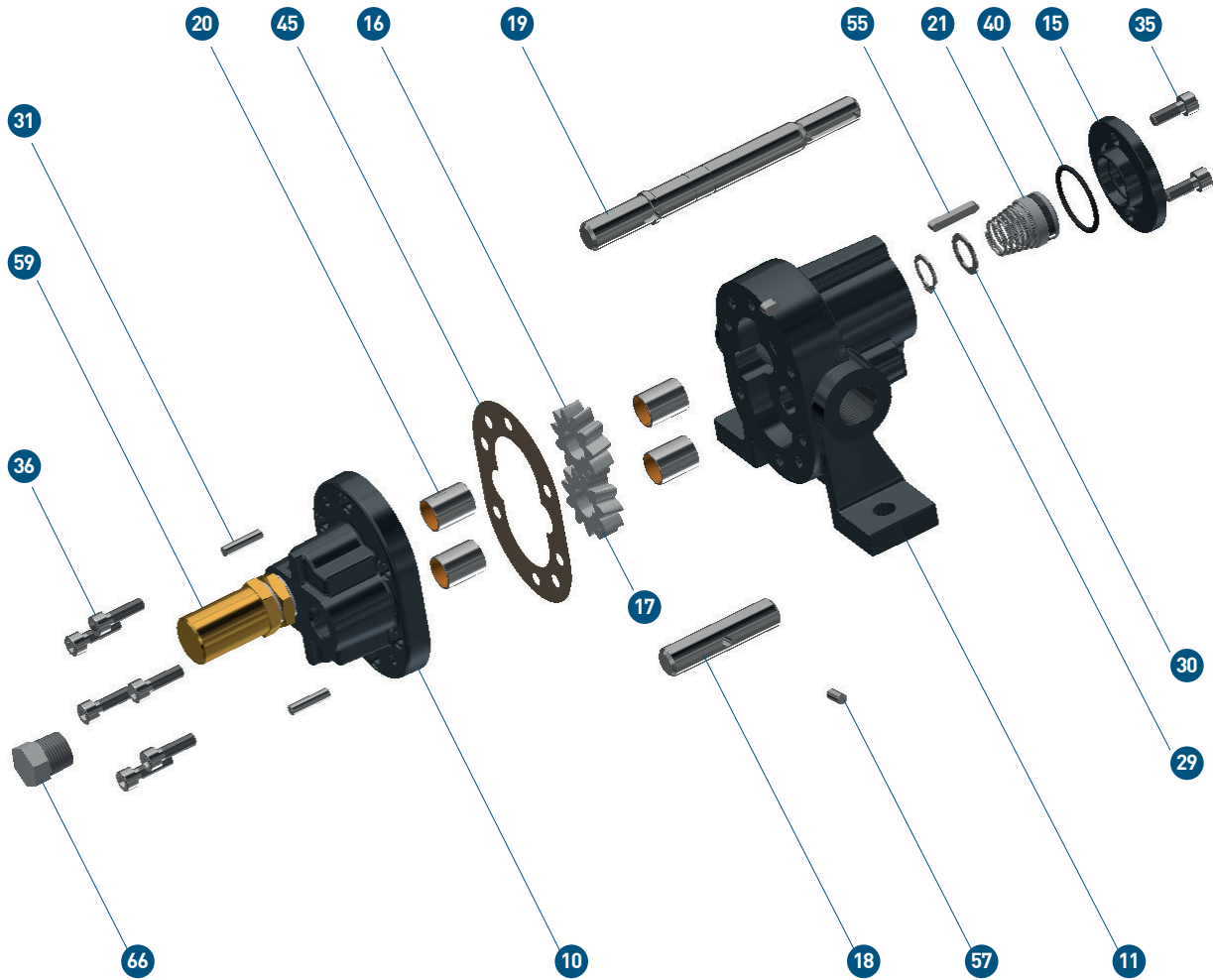

Fig. 308 - Pressure relief valve details

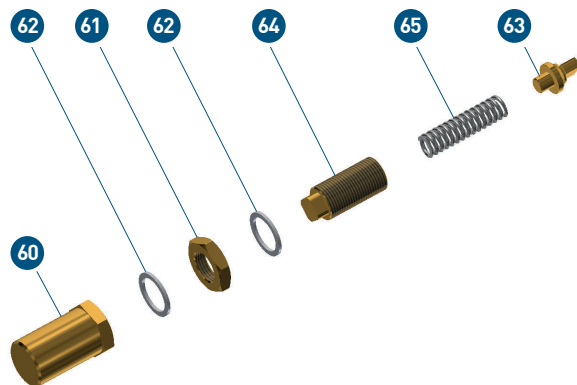

Fig. 522 - Packing seal details

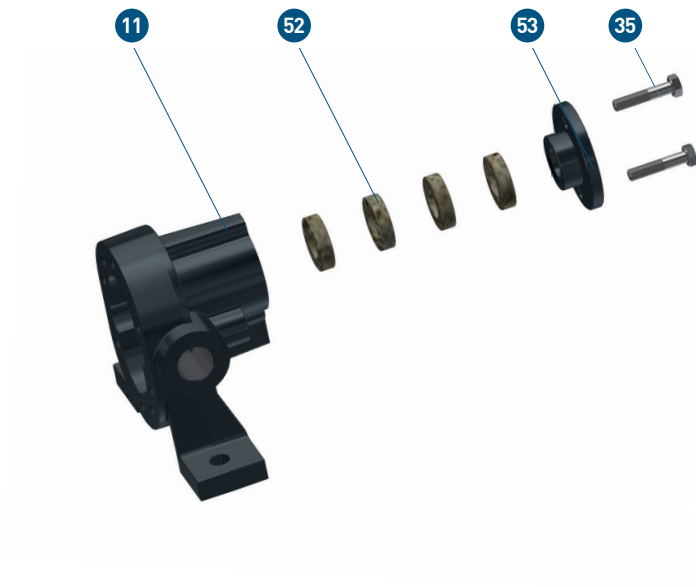
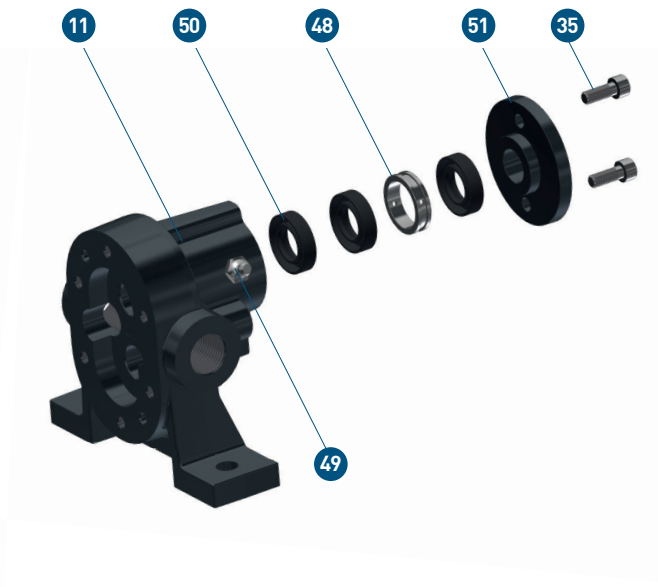

Fig. 523 - Lip seal details



Tab. 523 - B3-40, BC10-25 spare parts list

Ref.	Description	Ref.	Description	Ref.	Description	Ref.	Description
10	Pump rear cover	21	Mechanical seal	48	Lantern ring	59	Kit valve
11	Pump housing	29	Locking ring	49	Greaser	60	Valve cap
15	Mechanical seal housing	30	Ring seal	50	Lip seals	61	Valve locknut
16	Driving gear	31	Dowel pin	51	Lip seal housing	62	Valve washer
17	Driven gear	35	Screw	52	Packing	63	Valve poppet
18	Driven shaft	36	Screw	53	Packing seal housing	64	Valve adjusting screw
19	Driving shaft	40	O-ring	55	Feather key	65	Valve spring
20	Sleeve bushings	45	Cover flat gasket	57	Feather key	66	Threaded cap

Fig. 524 - B50-150; BC50-150

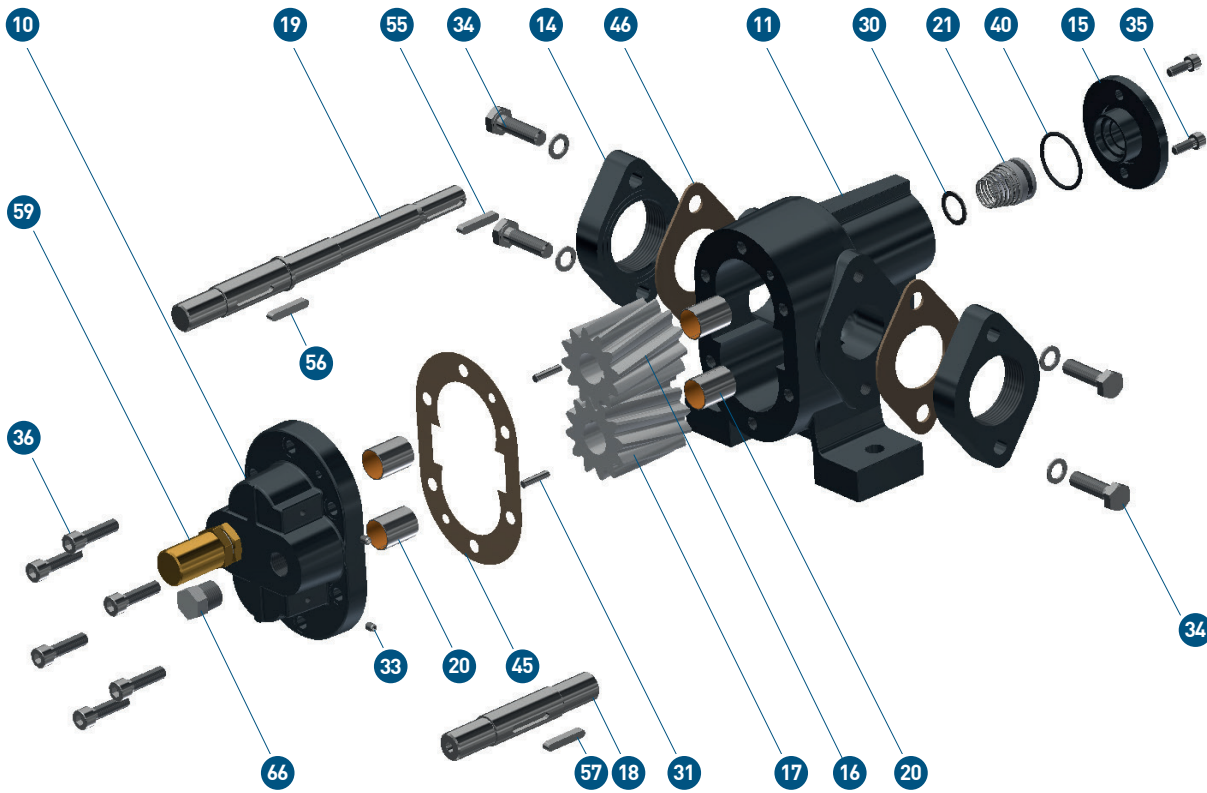

Fig. 308 - Pressure relief valve details

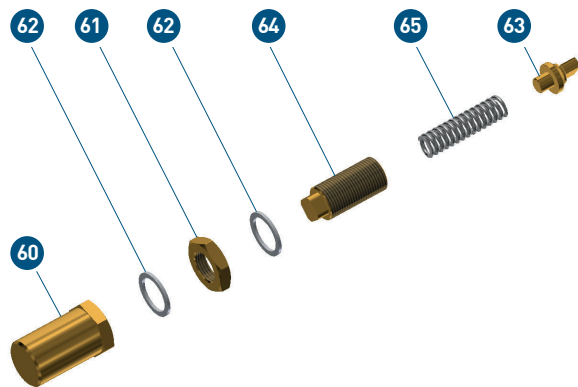
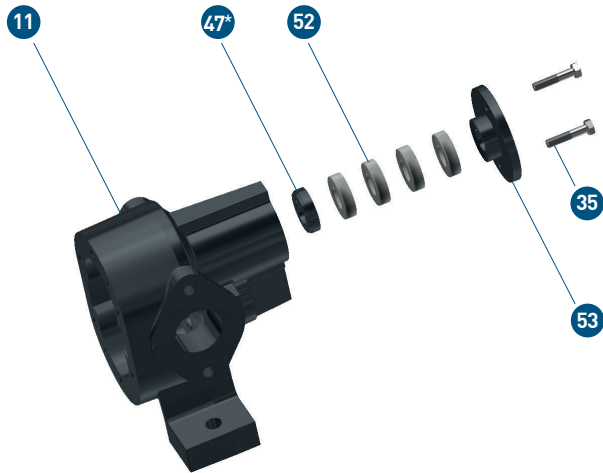
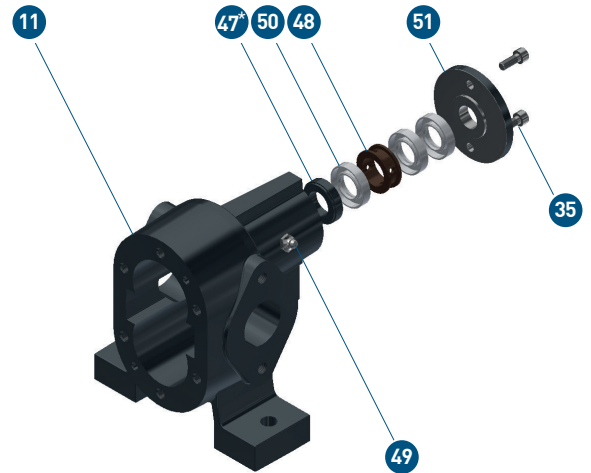

Fig. 525 – Packing seal details



(*) Only on size B50 -B70

Fig. 526 – Lip seal details



(*) Only on size B50-B70

Tab. 524 - B50-150, BC50-150 spare parts list

Ref.	Description	Ref.	Description	Ref.	Description	Ref.	Description
10	Pump rear cover	30	Ring seal	48	Lantern ring	60	Valve cap
11	Pump housing	31	Dowel pin	49	Greaser	61	Valve locknut
14	Flange	33	Grub screw	50	Lip seals	62	Valve washer
15	Mechanical seal housing	34	Bolt	51	Lip seal housing	63	Valve poppet
16	Driving gear	35	Screw	52	Packing	64	Valve adjusting screw
17	Driven gear	36	Screw	53	Packing seal housing	65	Valve spring
18	Driven shaft	40	O-ring	55	Feather key	66	Threaded cap
19	Driving shaft	45	Cover flat gasket	56	Feather key		
20	Sleeve bushings	46	Flange flat gasket	57	Feather key		
21	Mechanical seal	47*	Seal bottom ring	59	Kit valve		

(*) Only on size B50-B70

Fig. 527 - B200-600; BC200-400

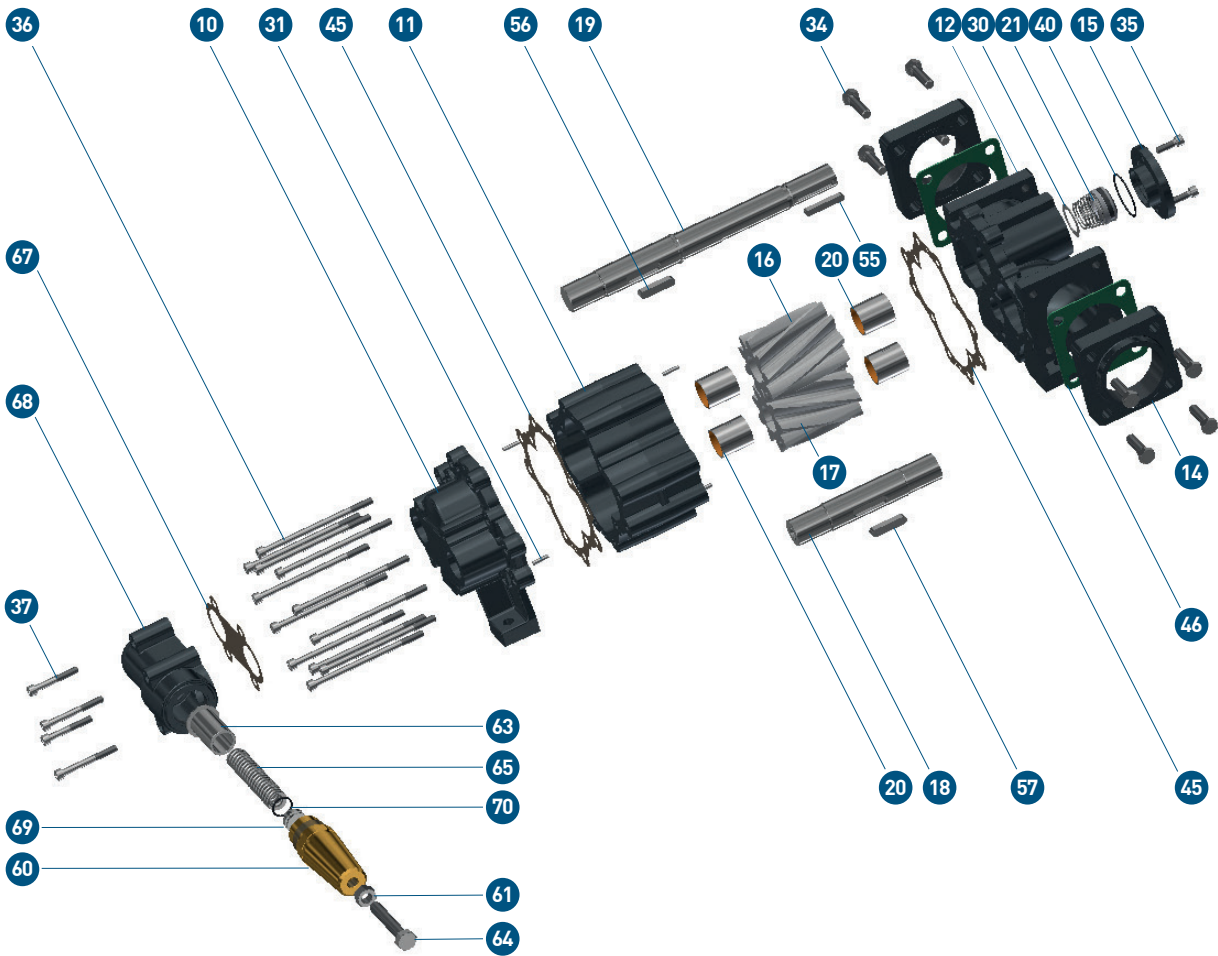

Fig. 528 - Packing seal details

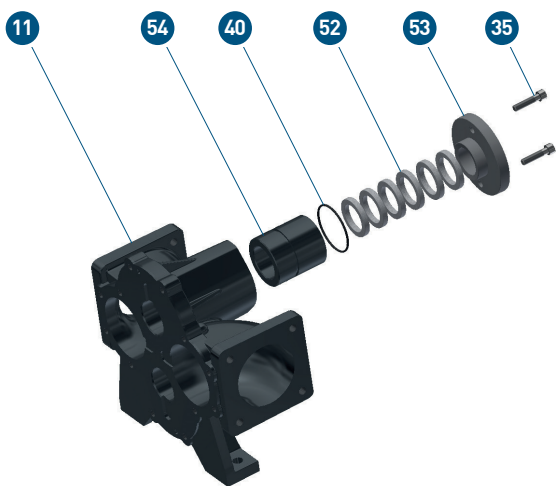

Fig. 529 - Lip seal details

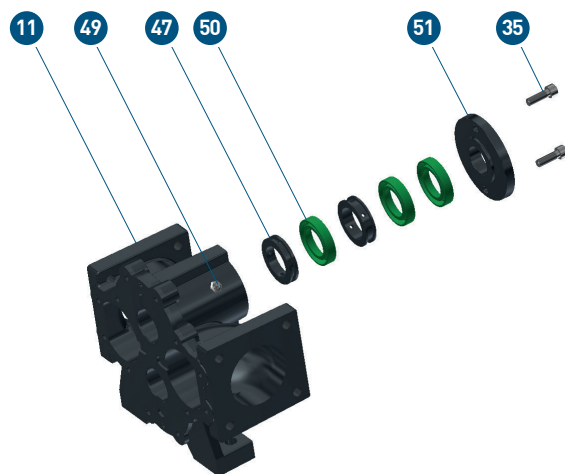
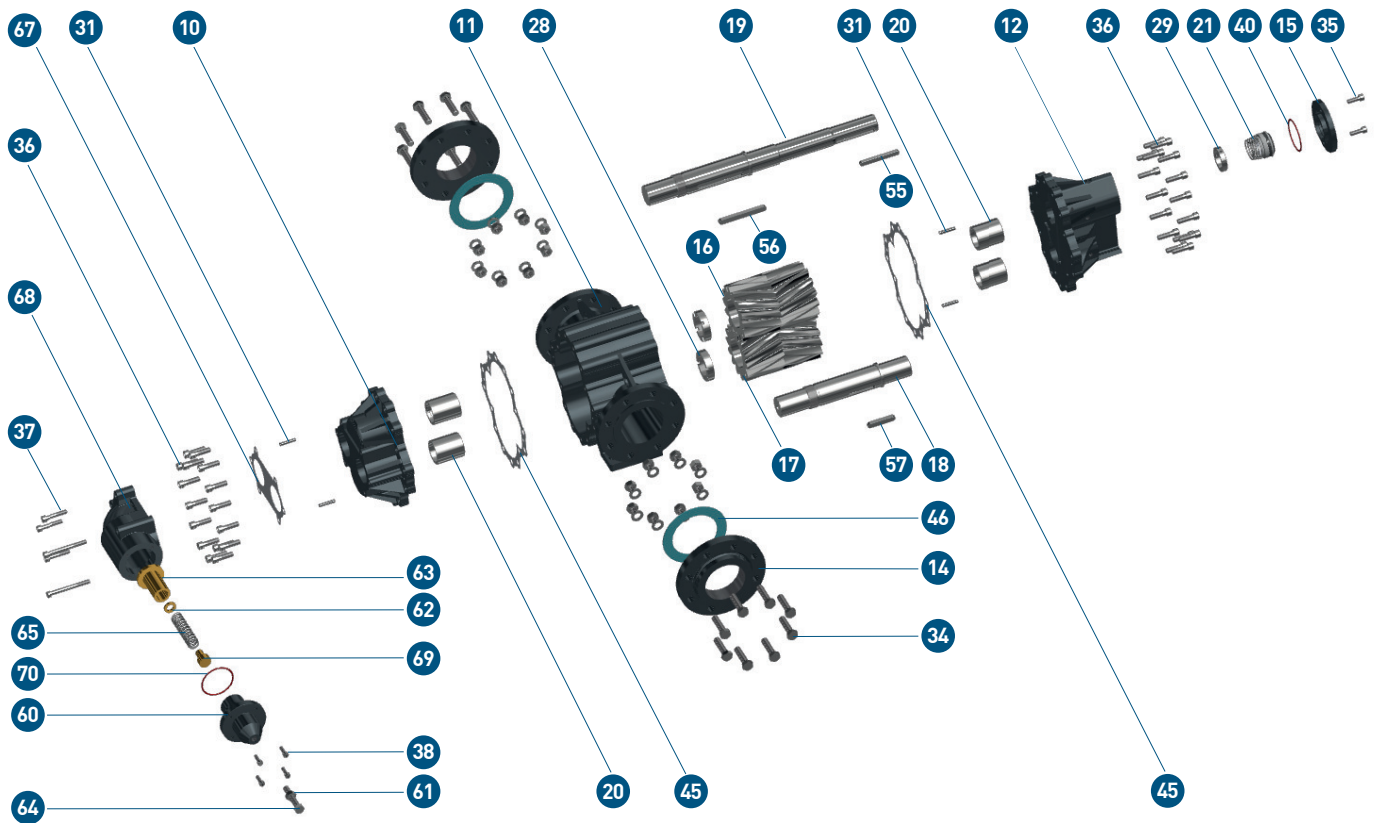

Fig. 530 - B1200-1600



Tab. 525 - B200-1600, BC200-400 spare parts list

Ref.	Description	Ref.	Description	Ref.	Description	Ref.	Description
10	Pump rear cover	28	Ring nut	46	Flange flat gasket	60	Valve cap
11	Pump housing	29	Locking ring	47	Seal bottom ring	61	Valve locknut
12	Pump front cover	30	Ring seal	49	Greaser	62	Valve washer
14	Flange	31	Dowel pin	50	Lip seals	63	Valve poppet
15	Mechanical seal housing	34	Bolt	51	Lip seal housing	64	Valve adjusting screw
16	Driving gear	35	Screw	52	Packing	65	Valve spring
17	Driven gear	36	Screw	53	Packing seal housing	67	Flat gasket
18	Driven shaft	37	Screw	54	Packing seal case	68	Valve housing
19	Driving shaft	38	Screw	55	Feather key	69	Spring cap
20	Sleeve bushings	40	O-ring	56	Feather key	70	O-ring
21	Mechanical seal	45	Cover flat gasket	57	Feather key		

Fig. 531 – MBM-MBMC

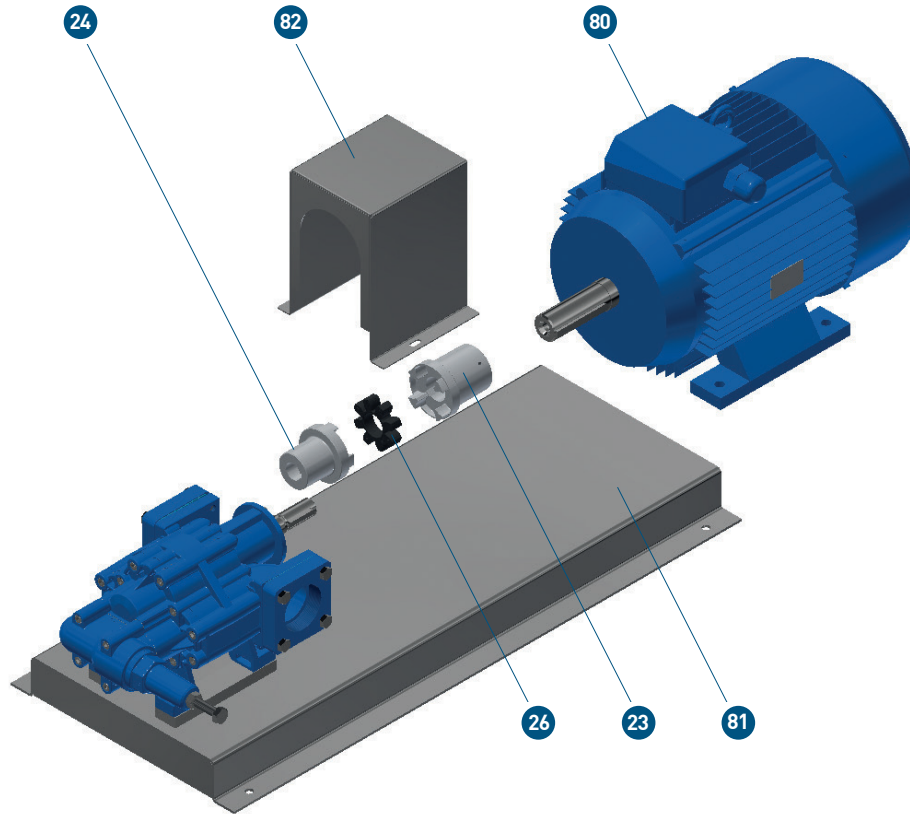

Tab. 526 - MBM, MBMC spare parts list

Ref.	Description
23	Half-coupling motor side
24	Half-coupling pump side
26	Spider
80	Electric motor
81	Skid
82	Coupling protection

Supplied by
Prime Fluid Management