

# Tank 8370

## High Chrome Dewatering Pump 50HZ



### Pump specifications

OUTPUT	HEAD	FLOW
37kW	Rated : 40m	Rated : 60L/s
50HP	Max : 50m	Max : 91.6L/s
<b>SHAFT SPEED</b>		2850rpm
<b>OUTLET</b>		200mm
<b>SOLID PASSAGE</b>		20mm

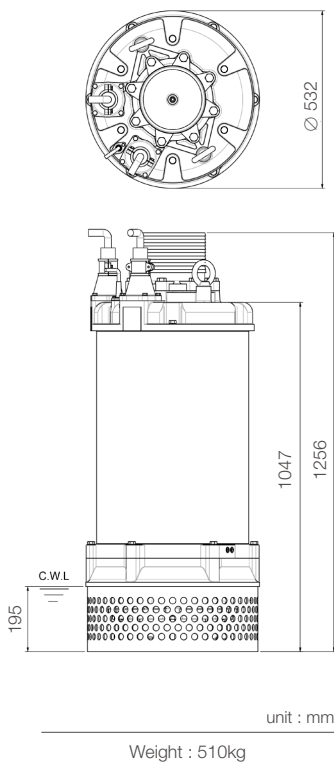
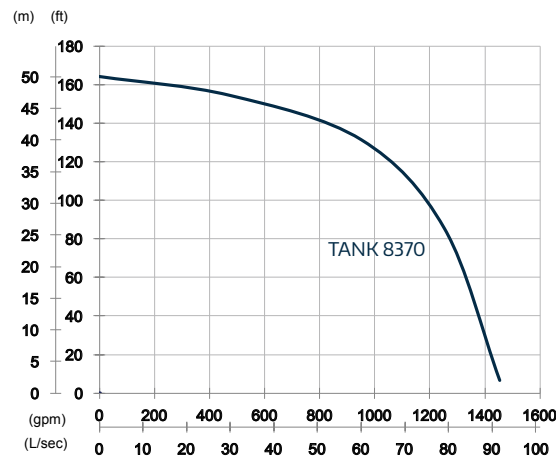

### Features

**Pump Type**  
 Electric Submersible Pumps  
 3-Phase

**Motor**  
 Type: Induction Motor  
 Poles: 2 Pole  
 Insulation: Class F  
 Protector: D.O.L. · Circle Thermal Protector  
 Star-Delta · Miniature Thermal Sensor  
 Starter: D.O.L.

**Lubricant**  
 Food Grade (ISO VG32)

**Impeller Type**  
 Closed

**Shaft Seal**  
 Double Mechanical Seal  
 Silicon Carbide VS Ceramic / Carbon

**Bearings**  
 C3 Shielded ball bearings

**Cable**  
 PVC (CSA Certified) / H07BQ-F  
 10m or longer upon request

**Materials**  
 Pump Casing: Ductile Iron  
 Impeller: Chromium Iron  
 Motor Frame: Gray Iron  
 Motor Shaft: Stainless Steel  
 Outer Case: Carbon Steel  
 Strainer: Carbon Steel

**Max. Liquid Temperature**  
 40°C

**Max. Submersion Depth**  
 20m

**pH Range**  
 pH 5 - pH 8