

Tank 222

High Chrome Dewatering Pump 50HZ



Pump specifications

OUTPUT	HEAD	FLOW
2.2kW	Rated : 15m	Rated : 5L/s
3HP	Max : 26m	Max : 8.3L/s
SHAFT SPEED		2850rpm
OUTLET		50mm
SOLID PASSAGE		9mm

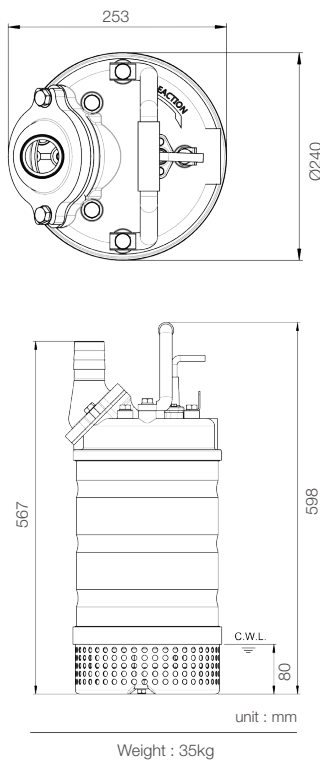
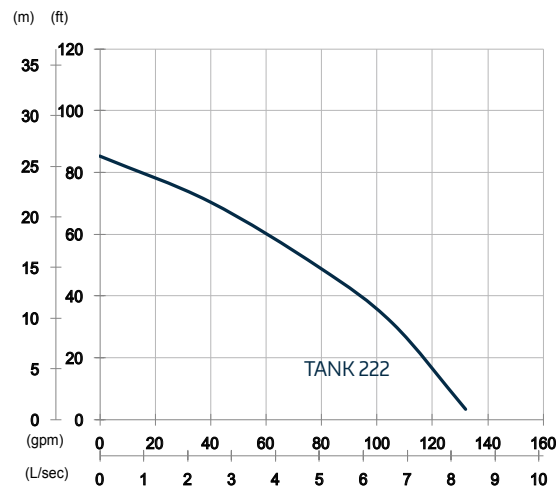

Features

Pump Type

Electric Submersible Pumps
 3-Phase

Motor

Type: Induction Motor
 Poles: 2 Pole
 Insulation: Class F
 Protector: Circle Thermal Protector
 Starter: D.O.L.

Lubricant

Food Grade (ISO VG32)

Impeller Type

Opened

Shaft Seal

Double Mechanical Seal
 Silicon Carbide VS Ceramic / Carbon

Bearings

C3 Shielded ball bearings

Cable

PVC (CSA Certified) / H07BQ-F
 10m or longer upon request

Materials

Pump Casing: Gray Iron
 Impeller: Chromium Iron
 Motor Frame: Stainless Steel
 Motor Shaft: Stainless Steel
 Strainer: Stainless Steel

Max. Liquid Temperature

40°C

Max. Submersion Depth

20m

pH Range

pH 5 - pH 8