

Tank 355

High Chrome Dewatering Pump 50HZ



Pump specifications

OUTPUT	HEAD	FLOW
5.5kW	Rated : 25m	Rated : 10L/s
7.5HP	Max : 32m	Max : 18.3L/s
SHAFT SPEED		2850rpm
OUTLET		80mm
SOLID PASSAGE		10mm

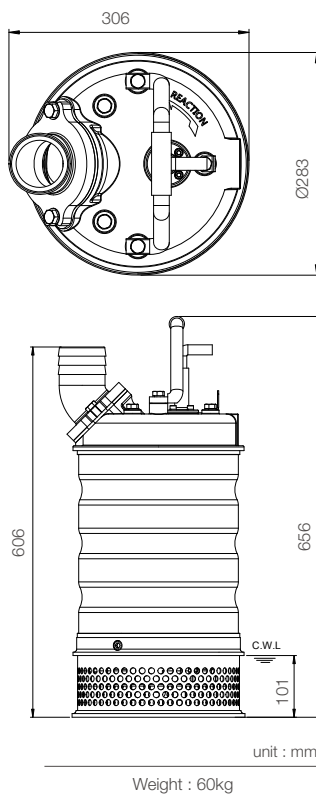
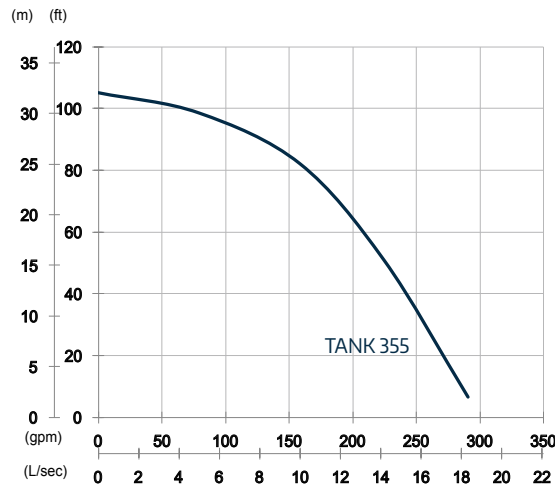

Features

Pump Type
Electric Submersible Pumps
3-Phase

Motor
Type: Induction Motor
Poles: 2 Pole
Insulation: Class F
Protector: Circle Thermal Protector
Starter: D.O.L.

Lubricant
Food Grade (ISO VG32)

Impeller Type
Opened

Shaft Seal
Double Mechanical Seal
Silicon Carbide VS Ceramic / Carbon

Bearings
C3 Shielded ball bearings

Cable
PVC (CSA Certified) / H07BQ-F
10m or longer upon request

Materials
Pump Casing: Gray Iron
Impeller: Chromium Iron
Motor Frame: Stainless Steel
Motor Shaft: Stainless Steel
Strainer: Stainless Steel

Max. Liquid Temperature
40°C

Max. Submersion Depth
20m

pH Range
pH 5 - pH 8