

Tank 455

High Chrome Dewatering Pump 50HZ



Pump specifications

OUTPUT	HEAD	FLOW
5.5kW	Rated : 15m	Rated : 16.7L/s
7.5HP	Max : 22.5m	Max : 29.1L/s
SHAFT SPEED		2850rpm
OUTLET		100mm
SOLID PASSAGE		10mm

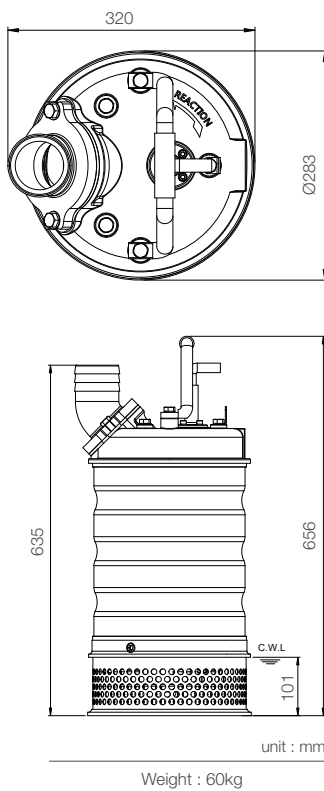
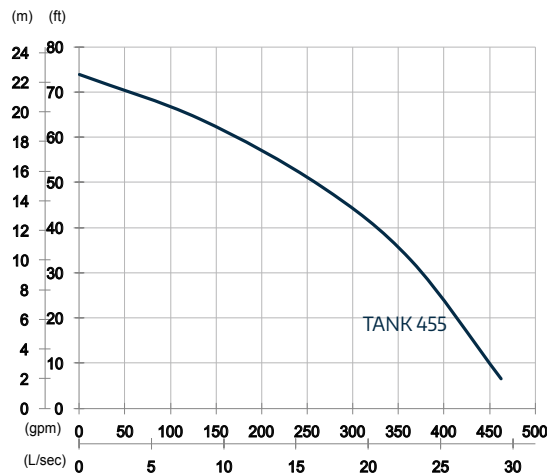

Features

Pump Type
 Electric Submersible Pumps
 3-Phase

Motor
 Type: Induction Motor
 Poles: 2 Pole
 Insulation: Class F
 Protector: Circle Thermal Protector
 Starter: D.O.L.

Lubricant
 Food Grade (ISO VG32)

Impeller Type
 Opened

Shaft Seal
 Double Mechanical Seal
 Silicon Carbide VS Ceramic / Carbon

Bearings
 C3 Shielded ball bearings

Cable
 PVC (CSA Certified) / H07BQ-F
 10m or longer upon request

Materials
 Pump Casing: Gray Iron
 Impeller: Chromium Iron
 Motor Frame: Stainless Steel
 Motor Shaft: Stainless Steel
 Strainer: Stainless Steel

Max. Liquid Temperature
 40°C

Max. Submersion Depth
 20m

pH Range
 pH 5 - pH 8