

# Tank Slim 230

## High Chrome Dewatering Pump 50HZ



### Pump specifications

| OUTPUT               | HEAD        | FLOW           |
|----------------------|-------------|----------------|
| 3kW                  | Rated : 30m | Rated : 3.3L/s |
| 4HP                  | Max : 35m   | Max : 8.3L/s   |
| <b>SHAFT SPEED</b>   |             | 2850rpm        |
| <b>OUTLET</b>        |             | 50mm           |
| <b>SOLID PASSAGE</b> |             | 7mm            |

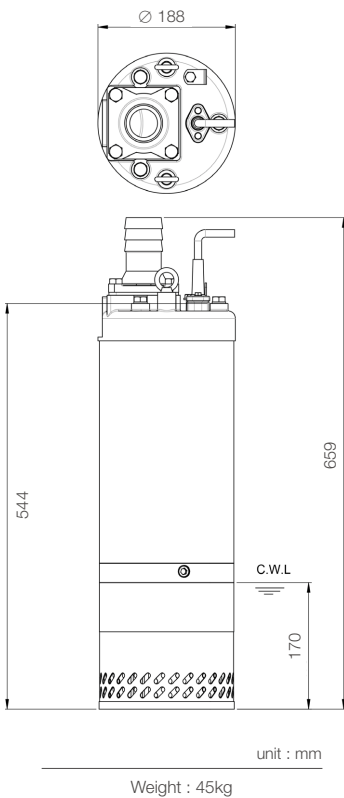
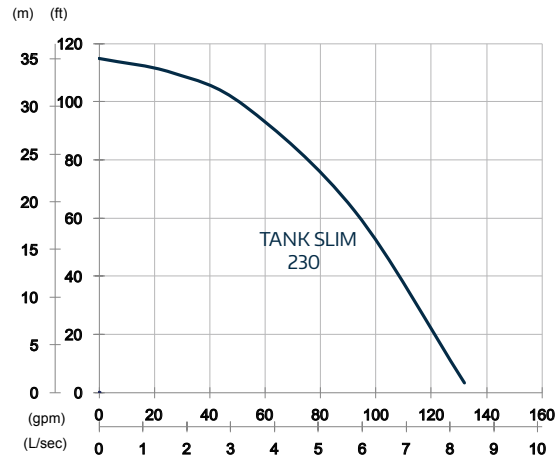

### Features

**Pump Type**  
 Electric Submersible Pumps  
 3-Phase

**Motor**  
 Type: Induction Motor  
 Poles: 2 Pole  
 Insulation: Class F  
 Protector: Circle Thermal Protector  
 Starter: D.O.L.

**Lubricant**  
 Food Grade (ISO VG32)

**Impeller Type**  
 Closed · Dual impellers

**Shaft Seal**  
 Double Mechanical Seal  
 Silicon Carbide VS Ceramic / Carbon

**Bearings**  
 C3 Shielded ball bearings

**Cable**  
 PVC (CSA Certified) / H07BQ-F  
 10m or longer upon request

**Materials**  
 Pump Casing: Gray Iron  
 Impeller: Chromium Iron  
 Motor Frame: Stainless Steel  
 Motor Shaft: Stainless Steel  
 Outer Case: Stainless Steel  
 Strainer: Stainless Steel

**Max. Liquid Temperature**  
 40°C

**Max. Submersion Depth**  
 20m

**pH Range**  
 pH 5 - pH 8