

Smart Lite Base 750

Handy and Residue Pump 50 HZ



Pump specifications

OUTPUT	HEAD	FLOW
0.75kW	Rated : 10m	Rated : 3.3L/s
1HP	Max : 15m	Max : 5.3L/s
SHAFT SPEED		2850rpm
OUTLET		50mm
SOLID PASSAGE		7mm

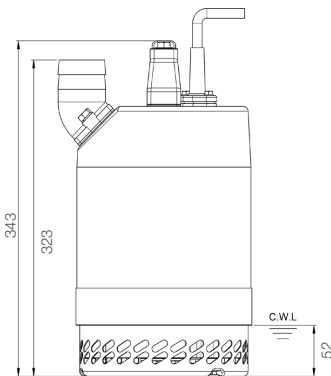
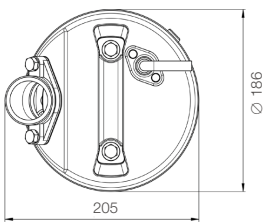
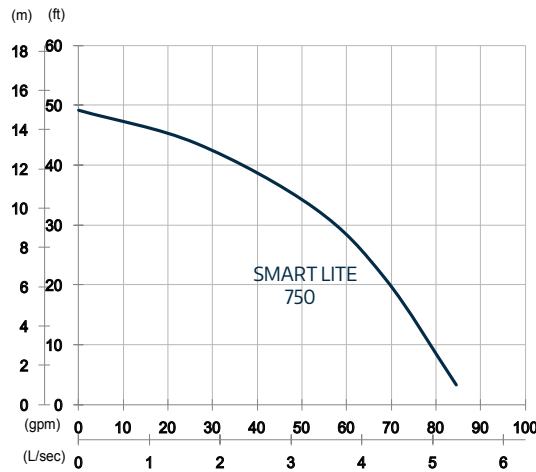

unit : mm
 Weight : 13kg

Features

Pump Type

Electric Submersible Pumps
 1-Phase

Motor

Type: Induction Motor
 Poles: 2 Pole
 Insulation: Class F
 Protector: Miniature Thermal Protector
 Starter: Capacitor-Run

Lubricant

Food Grade (ISO VG32)

Impeller Type

Semi-Vortex

Shaft Seal

Double Mechanical Seal
 Silicon Carbide VS Ceramic / Carbon

Bearings

C3 Shielded ball bearings

Cable

PVC (CSA Certified) / H07RN-F
 6m or longer upon request

Materials

Pump Casing: Gray Iron
 Impeller: Synthetic Polymers
 Motor Frame: Aluminum
 Motor Shaft: Stainless Steel
 Outer Case: Aluminum
 Strainer: Carbon Steel

Max. Liquid Temperature

40°C

Max. Submersion Depth

20m

pH Range

pH 5 - pH 8