

SIHI Multi

Type MSL, MSM

Modular multistage pumps



Description

SIHI^{multi} pumps are horizontal multistage centrifugal pumps of ring-section design, which meet the technical requirements of ISO 5199 / EN 25199.

The advanced modular design reduces the number of parts whilst maximising interchangeability.

Optimal selection of impeller diameter and diffuser size for each ensures that the pump closely match the required duty conditions.



Applications

Pumps of the SIHI^{multi} range meet the specific requirements of many applications, such as:

- Waterworks, and water supply
- Boiler feed
- Pressure boosting
- Irrigation
- High pressure cleaning
- Heating
- Condensate systems
- Reverse osmosis
- Chemical and Process
- and many more ...

Technical Data

Flowrate	max. 450 m ³ /h
Head	max. 630 m
Speed	max. 3600 rpm
Temperature	-10 to +180°C *
Pressure Rating	max. 63 bar
Shaft seal	- packed gland - mechanical seal
Direction of rotation	counter-clockwise, when viewed from discharge side

* 200°C as special design for example pump feet are mounted concentric in accordance to ISO 9905

Construction

Different hydraulic impeller and diffuser sizes can be installed in a standardised casing, thus enabling the pump to be designed exactly for the working point required. The first stage of each pump size is equipped with a suction impeller.

Axial thrust is hydraulically balanced by a patented balance drum system with a self-adjusting throttling device. Residual thrust is absorbed by a generously-sized angular-contact ball bearing. The balancing line is returned to the suction casing or in the upstream vessel. Standard suction casing construction is with axial or radial inlet nozzles.

A mechanical shaft seal is located on the drive side only. It can consist of a packed gland (cooled or uncooled, with external flushing connection), (cooled or uncooled) single-acting mechanical seal or (uncooled) double-acting mechanical seal.

The pump rotor is supported on the drive side by grease-lubricated anti-friction bearings and on the suction side by a self-adjusting sleeve bearing lubricated by the pumped liquid.

The pump is normally driven from the discharge side. As option the pump can be driven from the suction side in which case an antifriction inboard/outboard bearing is provided.

The casing components are sealed by O-rings. The pump casings are held together by external tie rods. The pump feet are mounted to the suction and discharge casings in such a manner that the suction casing (for suction casings with radial branch) and discharge casing can be swung to suit the installation conditions.

All pump sizes can be provided with one or more dummy stages, if required.

Options

- Special materials
- Monitoring Systems

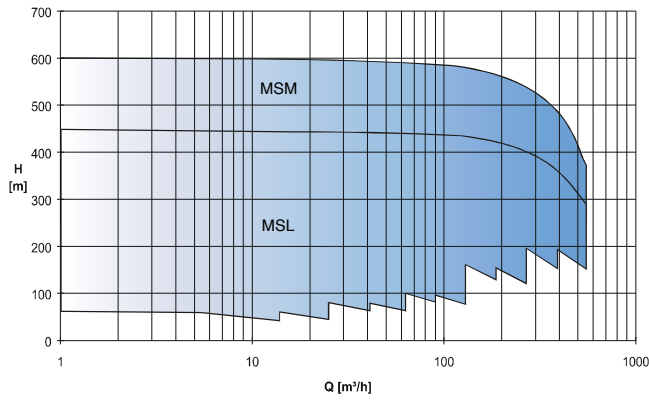

Suction Impeller

First stage impeller ensures reliable operation with low NPSH conditions.

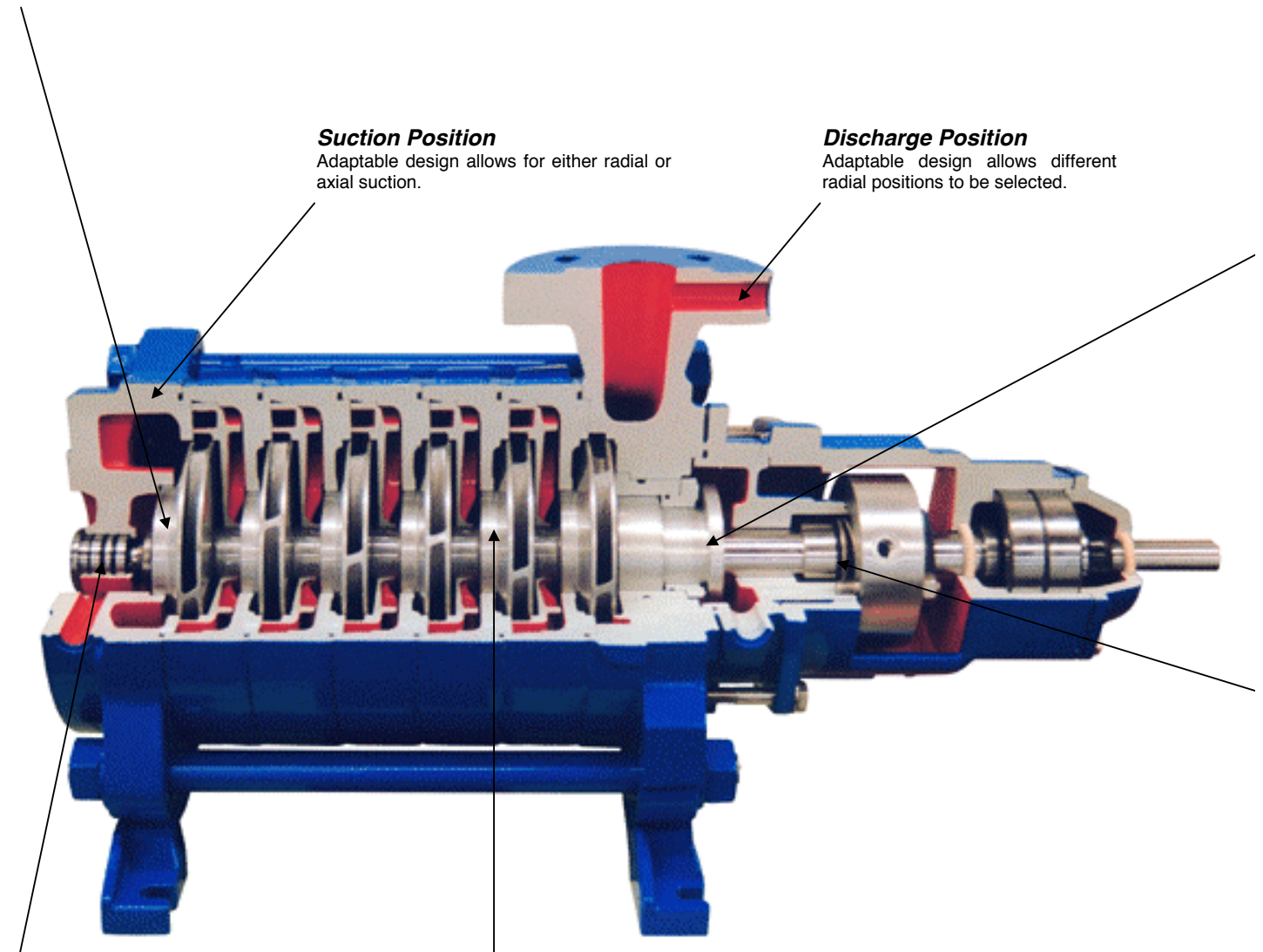

Suction Position

Adaptable design allows for either radial or axial suction.

Discharge Position

Adaptable design allows different radial positions to be selected.

Product Lubricated Sleeve Bearing

Self-aligning bearing for higher reliability

Modular Design

Modular geometry of impellers/diffusers permits optimal hydraulic design matching all duty conditions.

New Design of Balance Drum System

This new, patented design combines a balance drum with a self-adjusting throttling device. The benefits include:

- greatly reduced re-circulation flow in the balance line
- same balance drum system for different number of stages
- high efficiency, lower power consumption
- lesser wear rate as this system does not rely on tight, wear-sensitive clearances to control the re-circulation flow

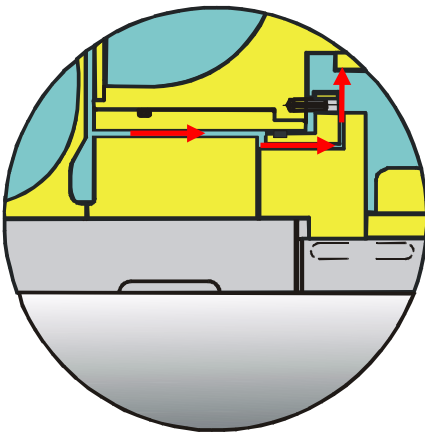

Shaft Sealing

- uncooled and cooled single-acting mechanical seal
- uncooled double acting mechanical seal
- uncooled or cooled packed gland

more ... for less ...

- ***Reduced life-cycle cost***
 - Enhanced efficiency with the balance drum system
 - Only one shaft seal
 - Lower power consumption
- High reliability
- ***Ease of maintenance***
 - Simple dismantling and assembly
- ***Minimised wear***
 - Reduced usage of spare parts
- ***Global service network***
 - Established local Service Centres around the world

Range Coverage 50 Hz

n = 1450 rpm

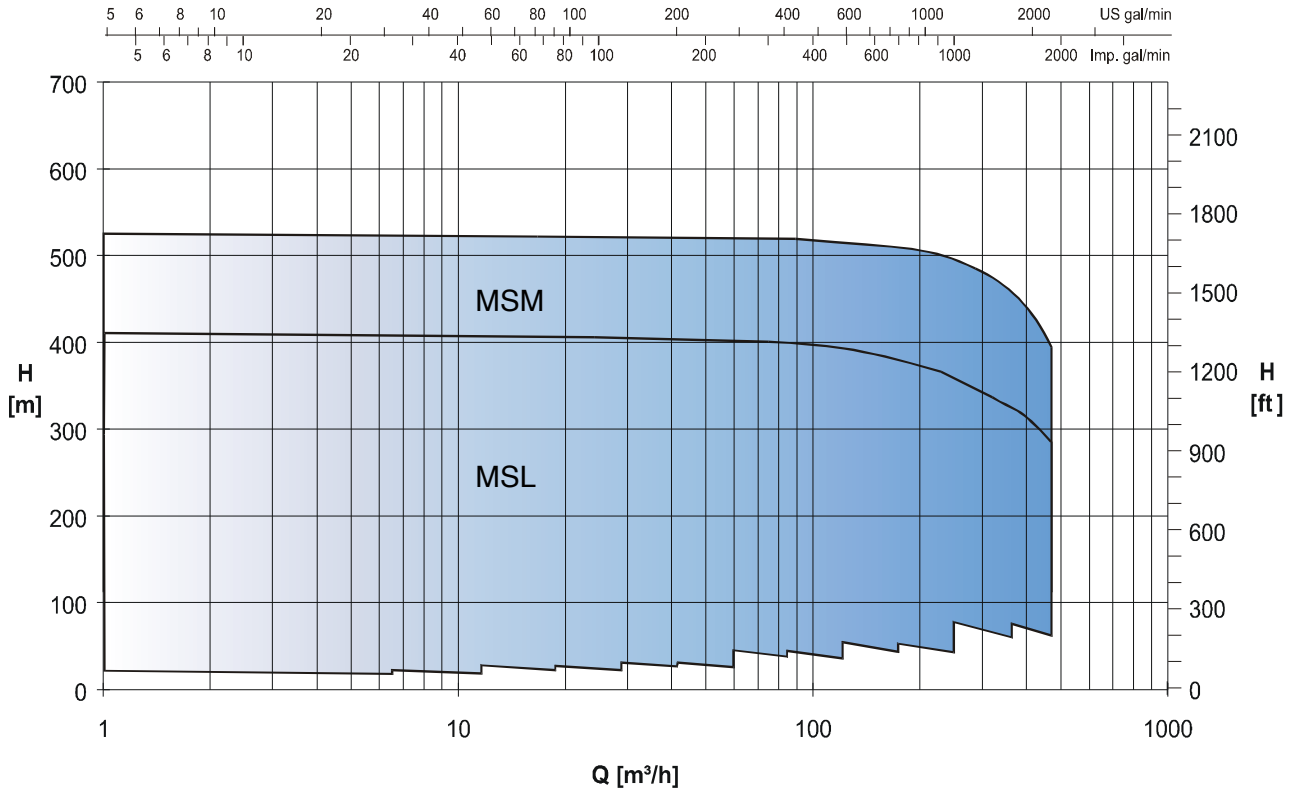

n = 2950 rpm

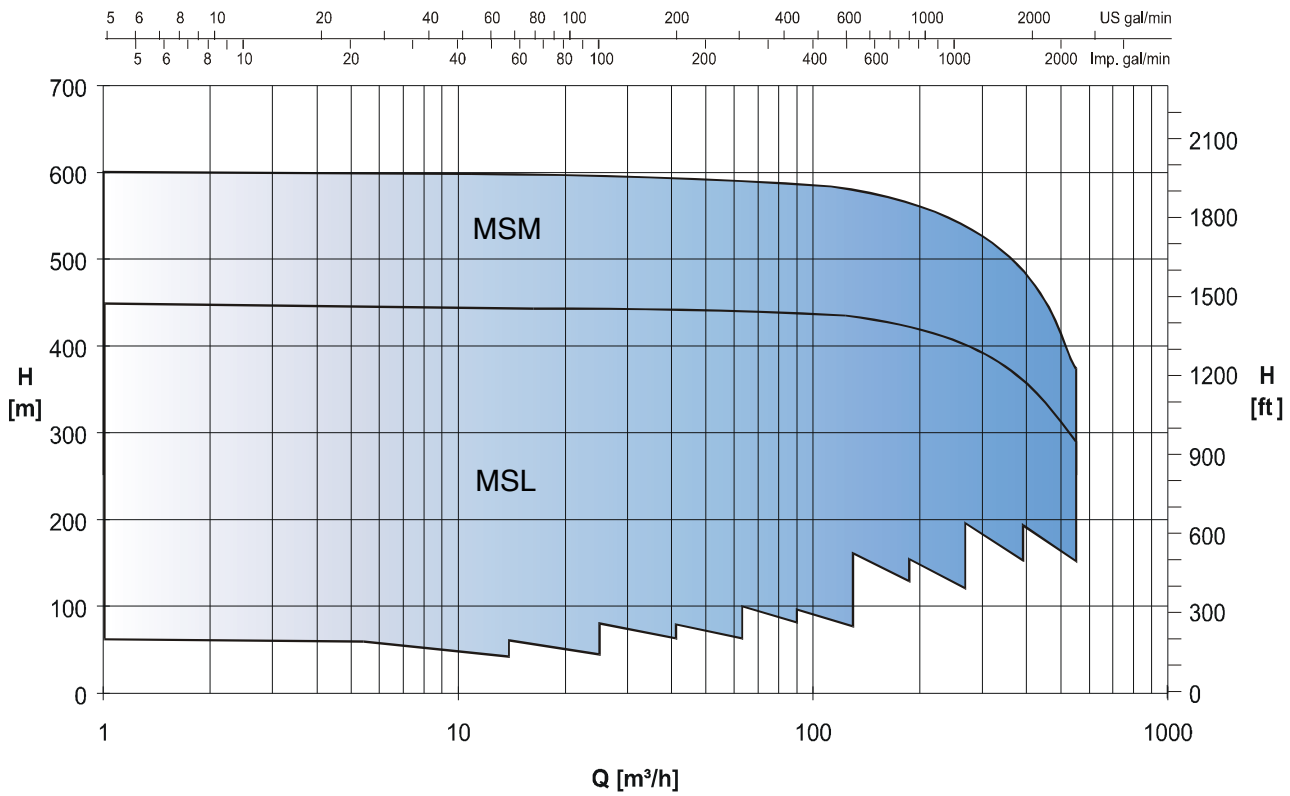

Range Coverage 60 Hz

n = 1750 rpm

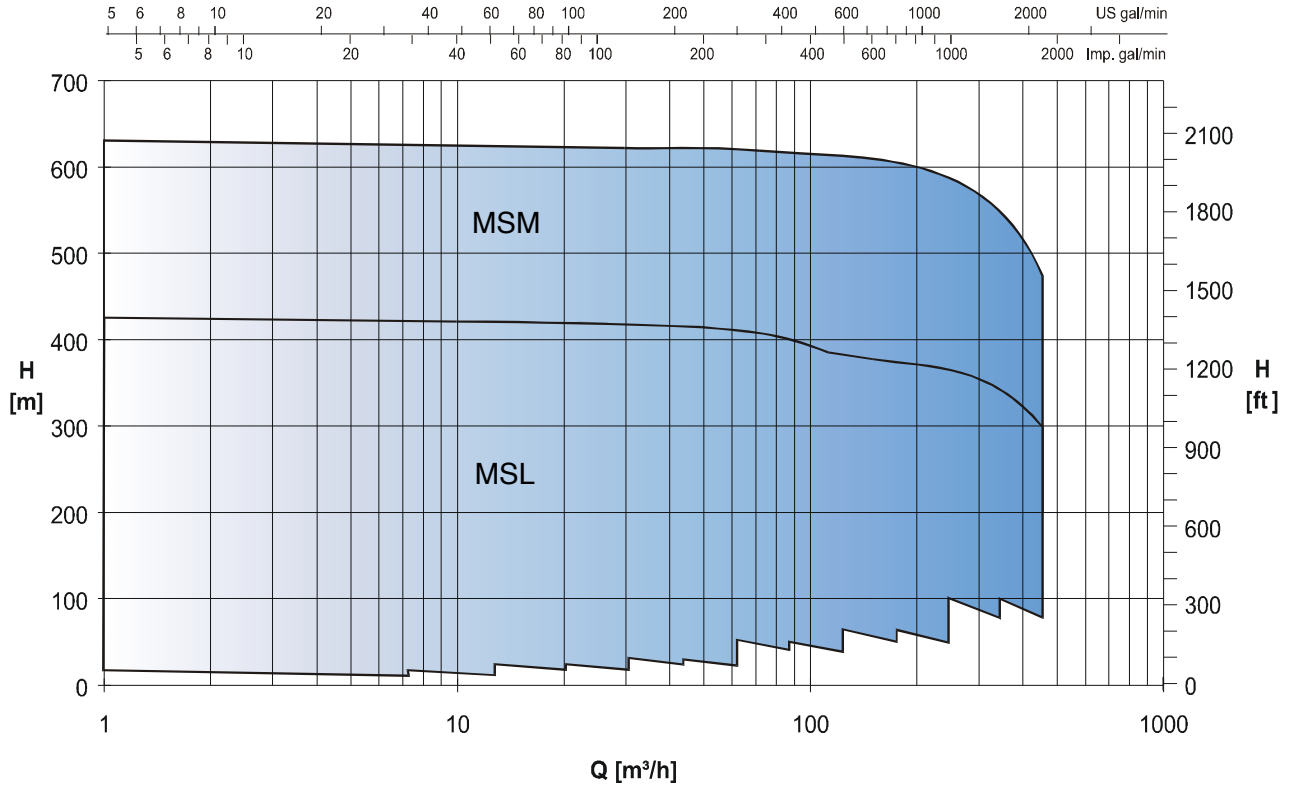

n = 3550 rpm

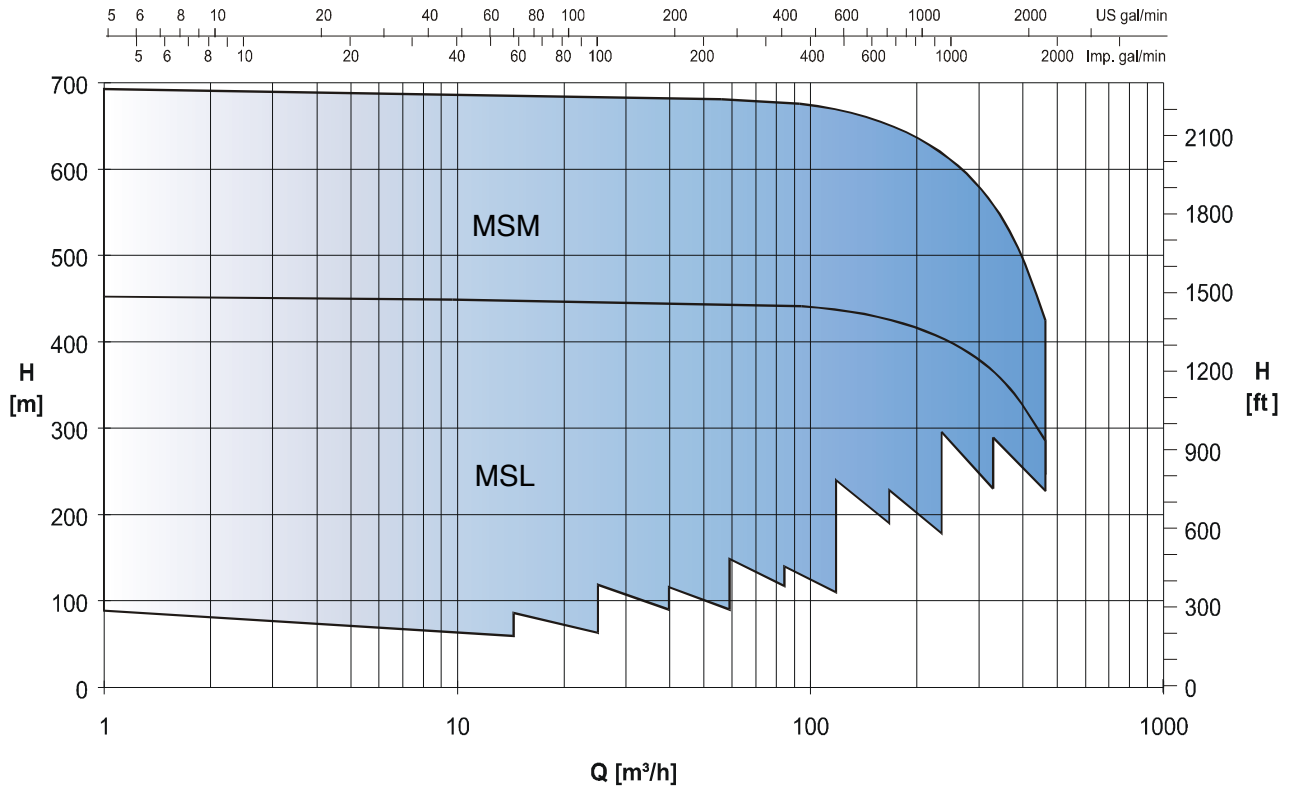

Nozzle Position (viewed from drive end)

Discharge Casing

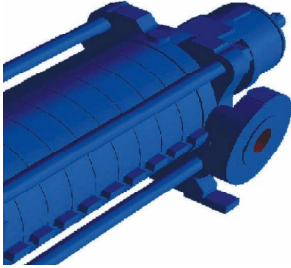

radial horizontal left



radial top



radial horizontal right

every combination of suction and discharge casing is possible

Suction casing

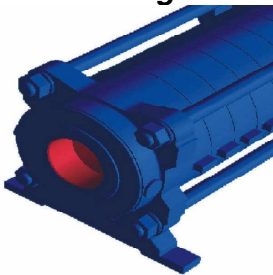

axial

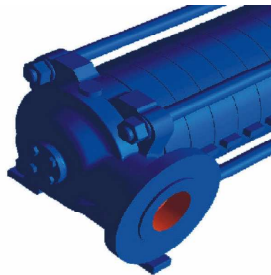

radial horizontal left

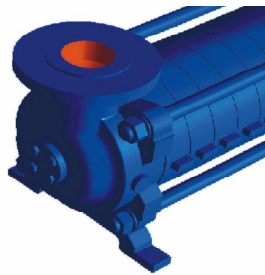

radial top

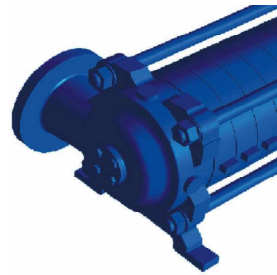

radial horizontal right

Flange Dimensions

ISO/EN/DIN

Pump Size	Nominal Size DN (mm)			Flange Shape/Nominal Pressure PN			
	suction side		discharge side	Casing Material			
	axial	radial		Cast Iron, Ductile Iron		Chrome Steel, Stainless Steel	
				suction side	discharge side	suction side	discharge side
032	80	50	32	DIN EN 1092 - 2, PN 16, PN 25	DIN EN 1092 - 2, PN 40 DIN 2546, PN 63	DIN EN 1092 - 2, PN 16, PN 25, DIN 2543, PN 16 DIN 2544 PN 25	DIN 2545, PN 40 DIN 2546, PN 63
050	100	80	50				
065	125	100	65				
100	150	125	100				
125	200	150	125				
150	200	200	150				

ANSI

Pump size	Nominal Size DN (inch)			Flange Shape/Nominal Pressure PN			
	suction side		discharge side	Casing Material			
	axial	radial		Cast Iron, Ductile Iron		Chrome Steel, Stainless Steel	
				suction side	discharge side	suction side	discharge side
032	3"	2"	1 ¼"	ANSI B 16.1, 250 FF	ANSI B 16.1, 250 RF	ANSI B 16.5, 300 RF	ANSI B 16.5, 300 RF, 600 RF
050	4"	3"	2"				
065	5"	4"	2 ½"				
100	6"	5"	4"				
125	8"	6"	5"				
150	8"	8"	6"				

Shaft Sealing

Mechanical seal arrangement

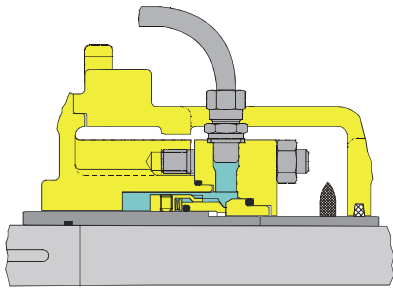

uncooled, balanced

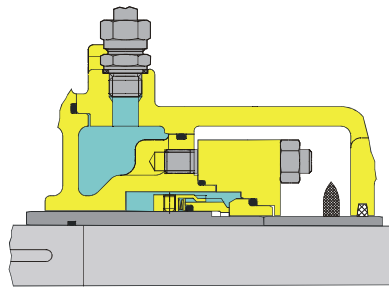

cooled, balanced

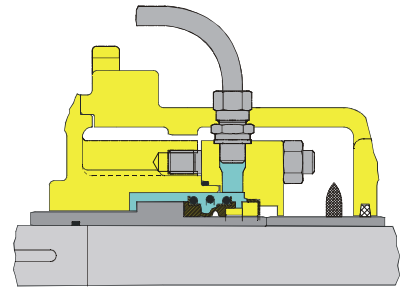

uncooled, unbalanced

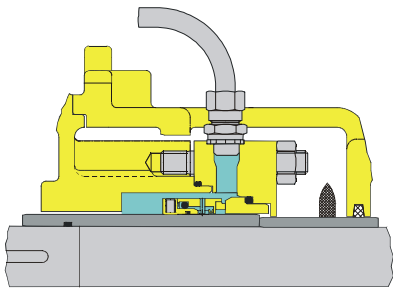

uncooled, balanced STERLING^{GNZ} seal

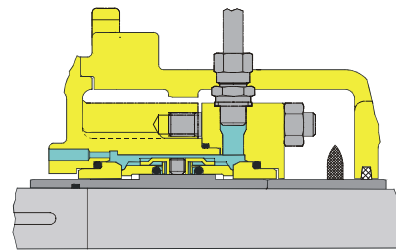

uncooled, double „back-to-back“

Packed gland arrangement

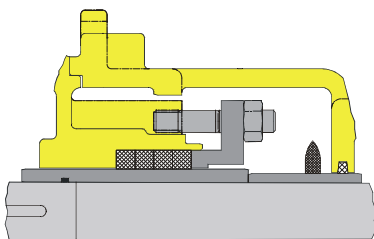

uncooled

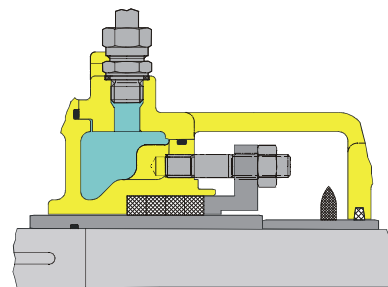

with jacket-cooling

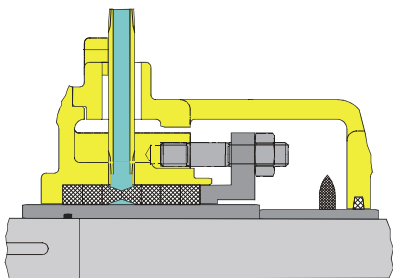

with external flushing

Sectional Drawing MSL, MSM with axial Inlet

Size 032 and 050

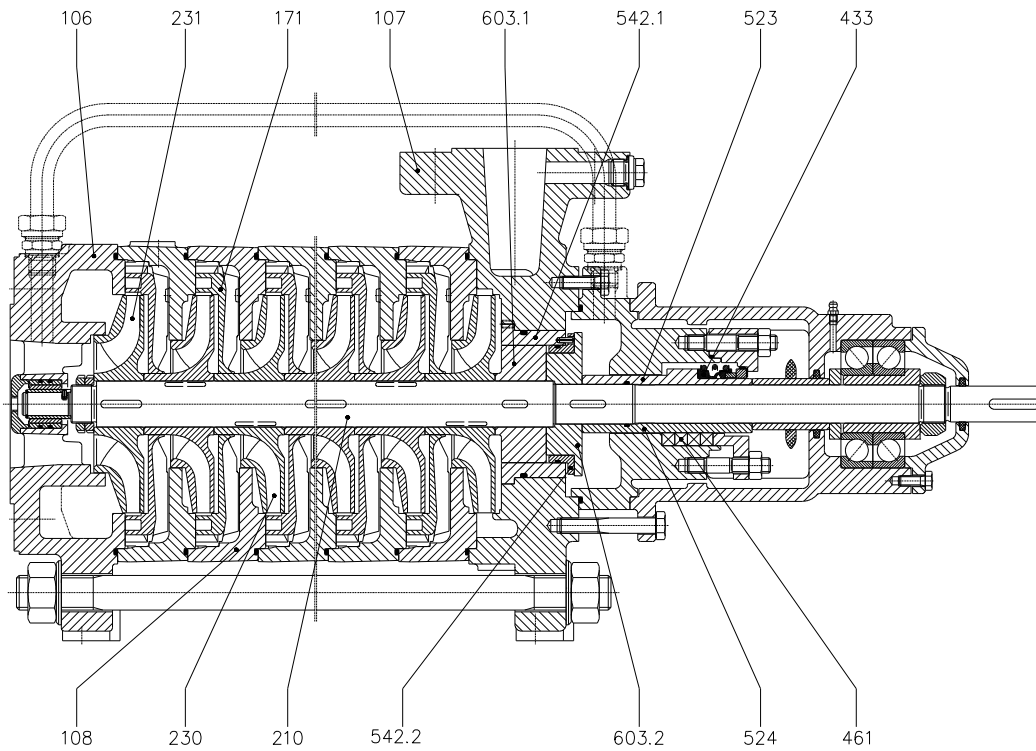

Size 065 and 100

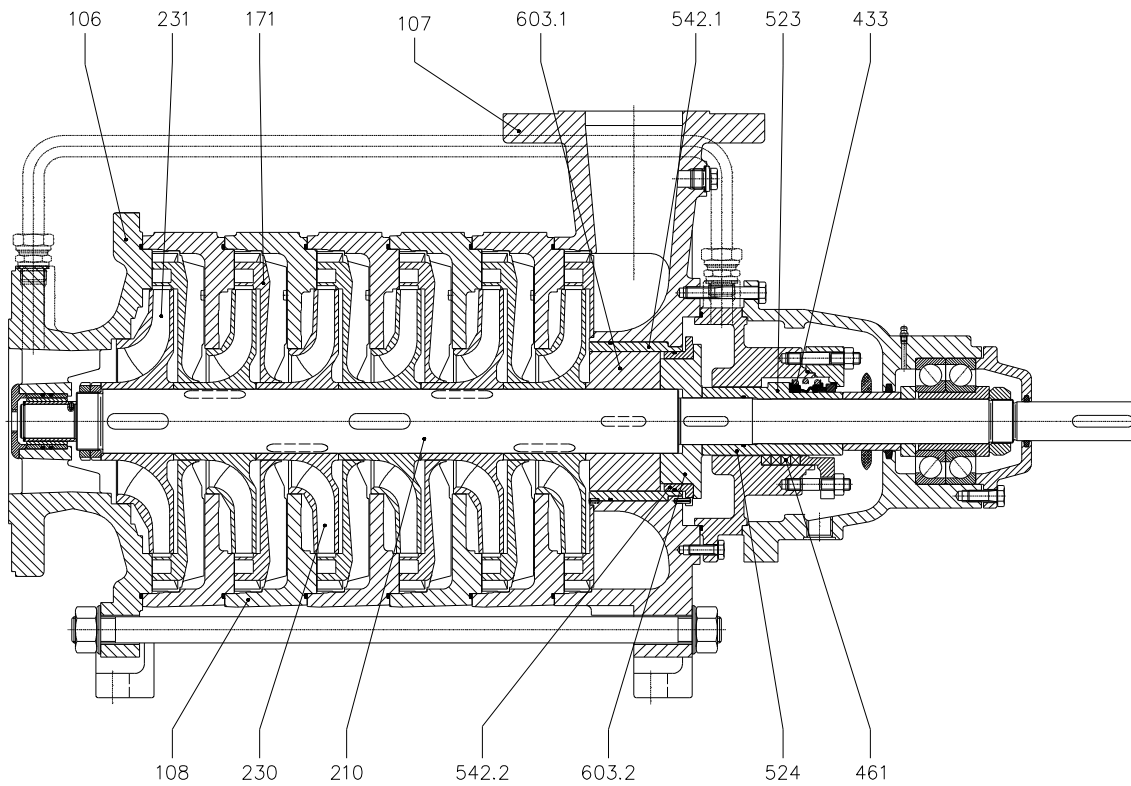

Sectional Drawing MSL, MSM with axial Inlet

Size 125

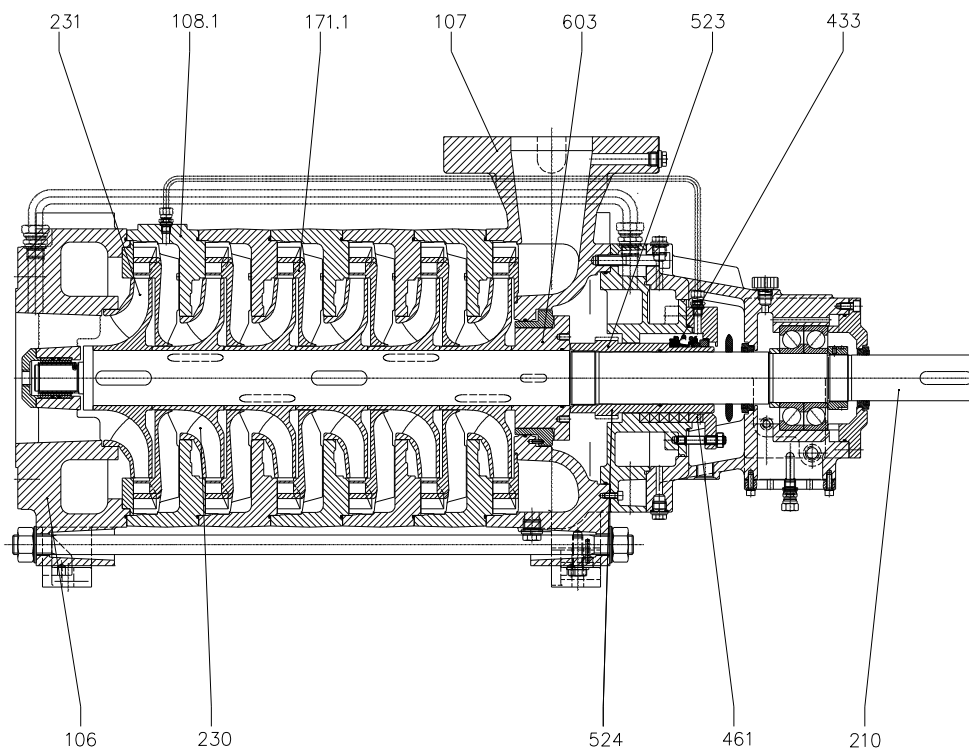

Size 150

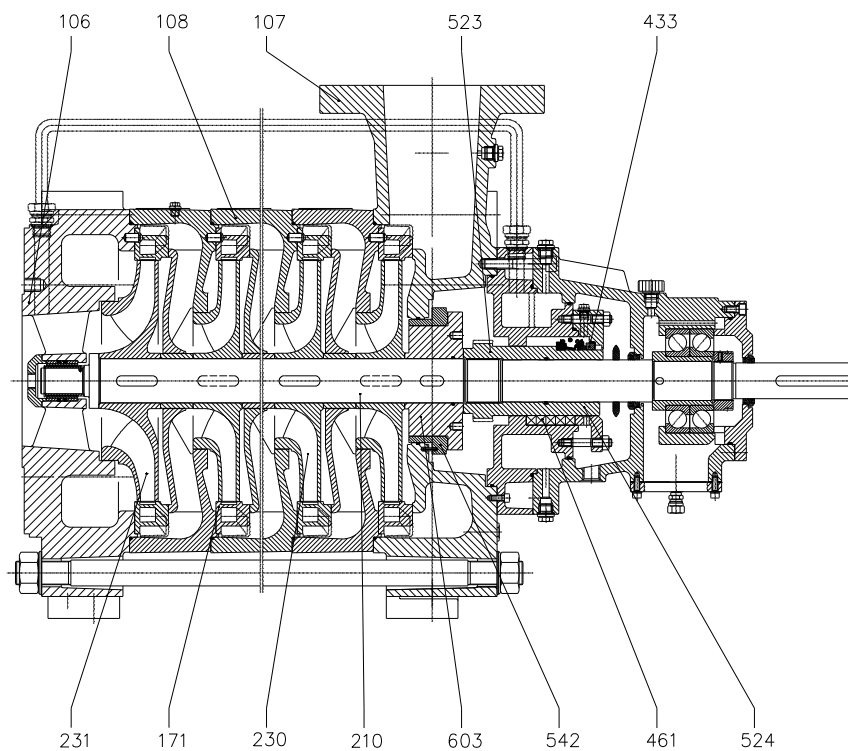

Sectional Drawing MSL, MSM with radial Inlet

Size 032 and 050

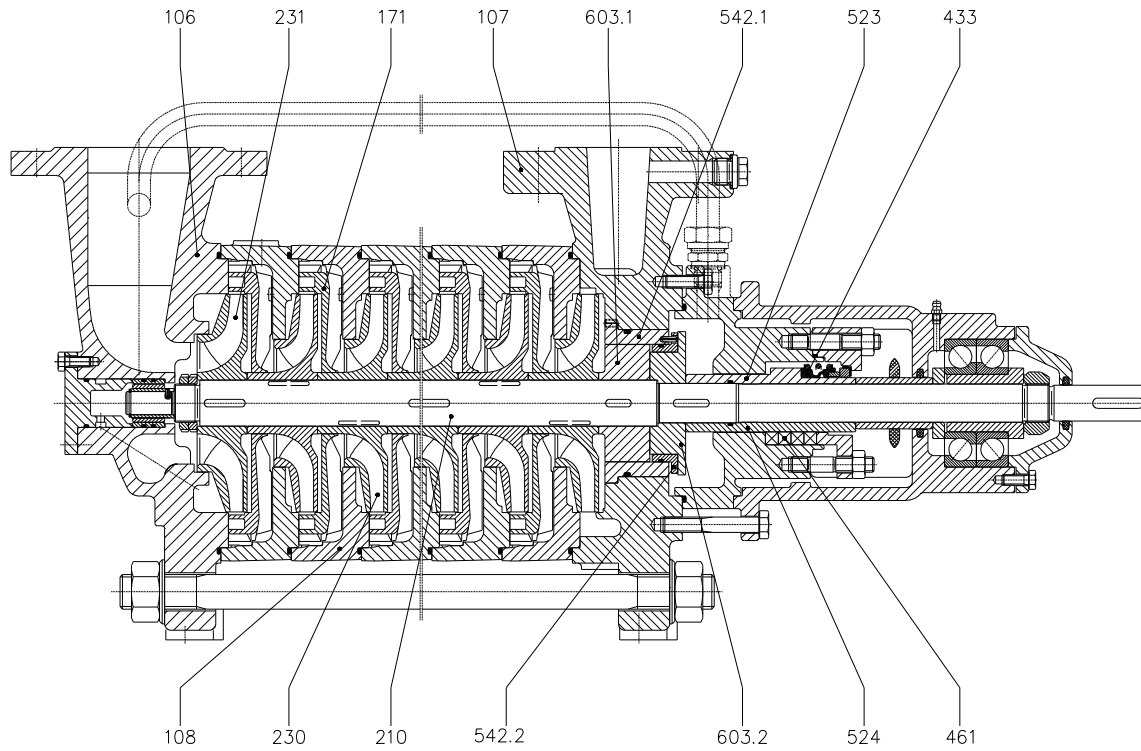

Size 065 and 100

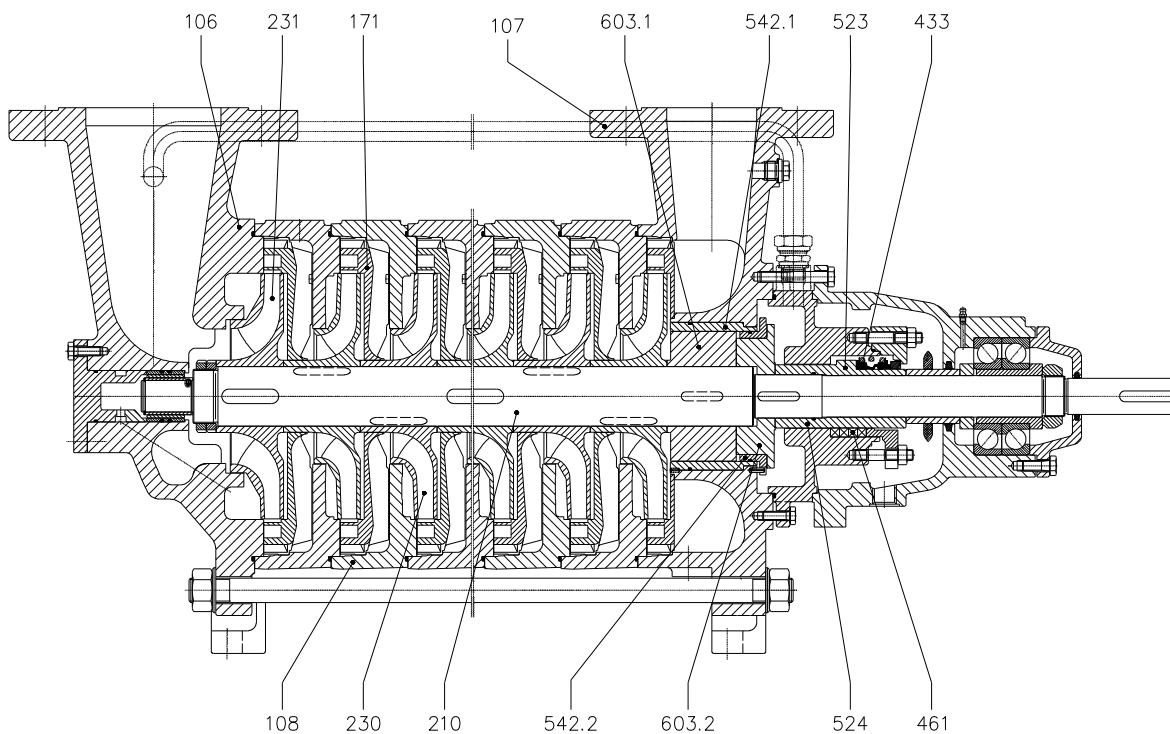

Sectional Drawing MSL, MSM with radial Inlet

Size 125

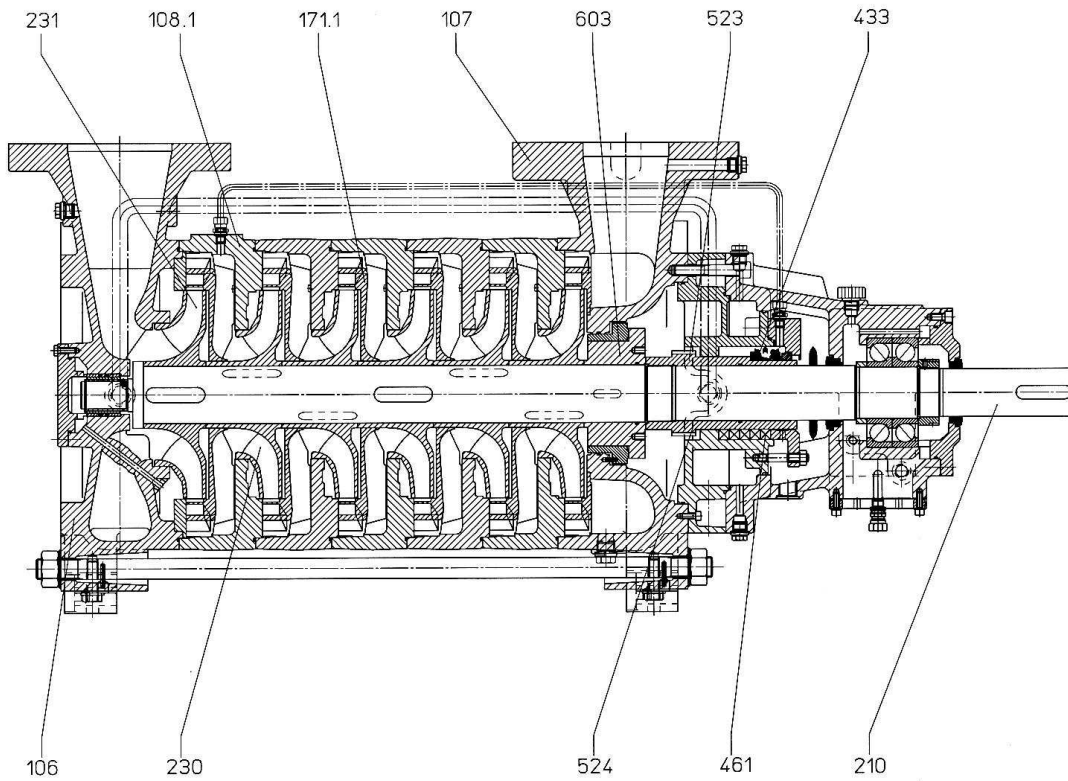

Size 150

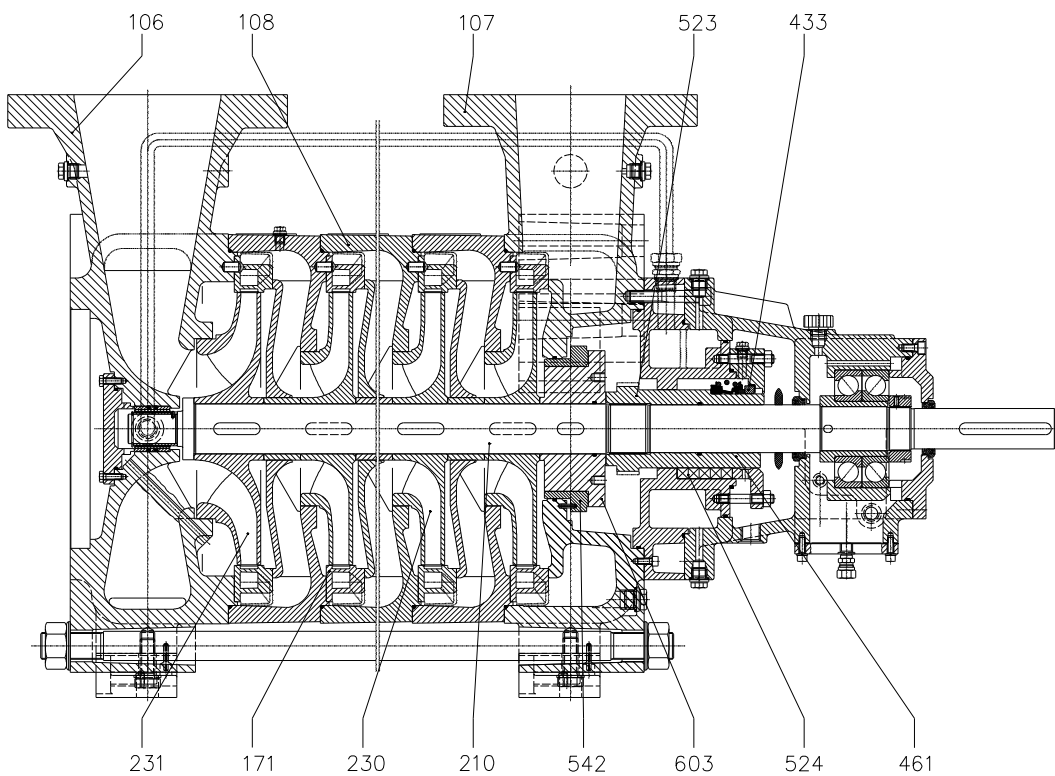

Sectional Drawing MSL, MSM with radial Inlet (drive on suction side)

Size 032 and 050

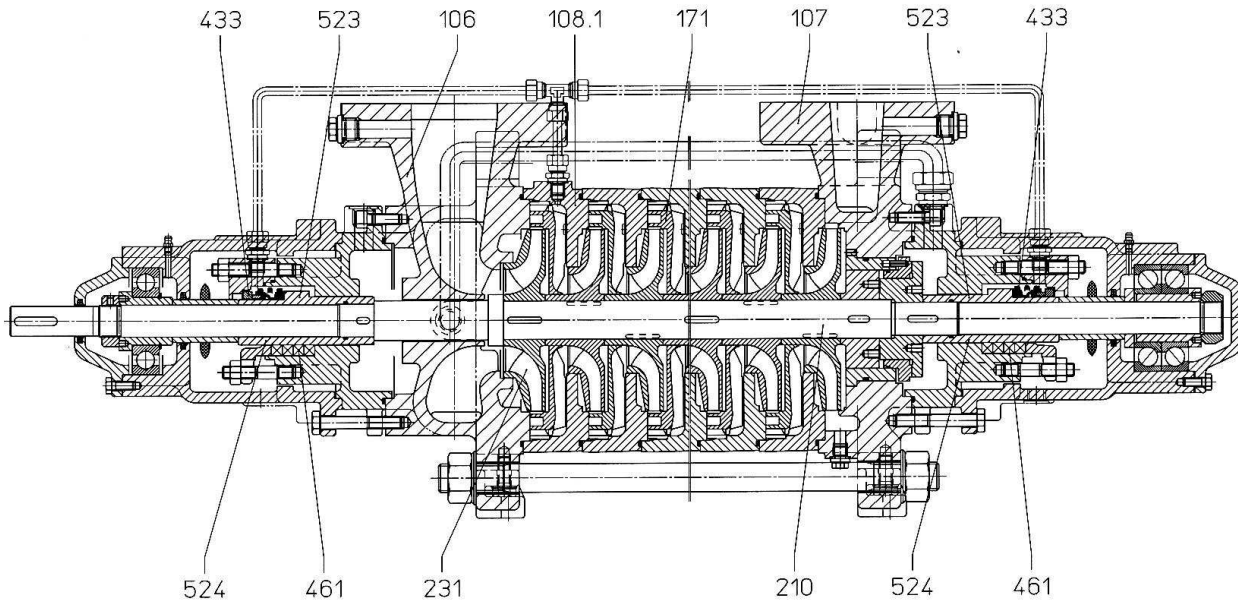

Size 065 and 100

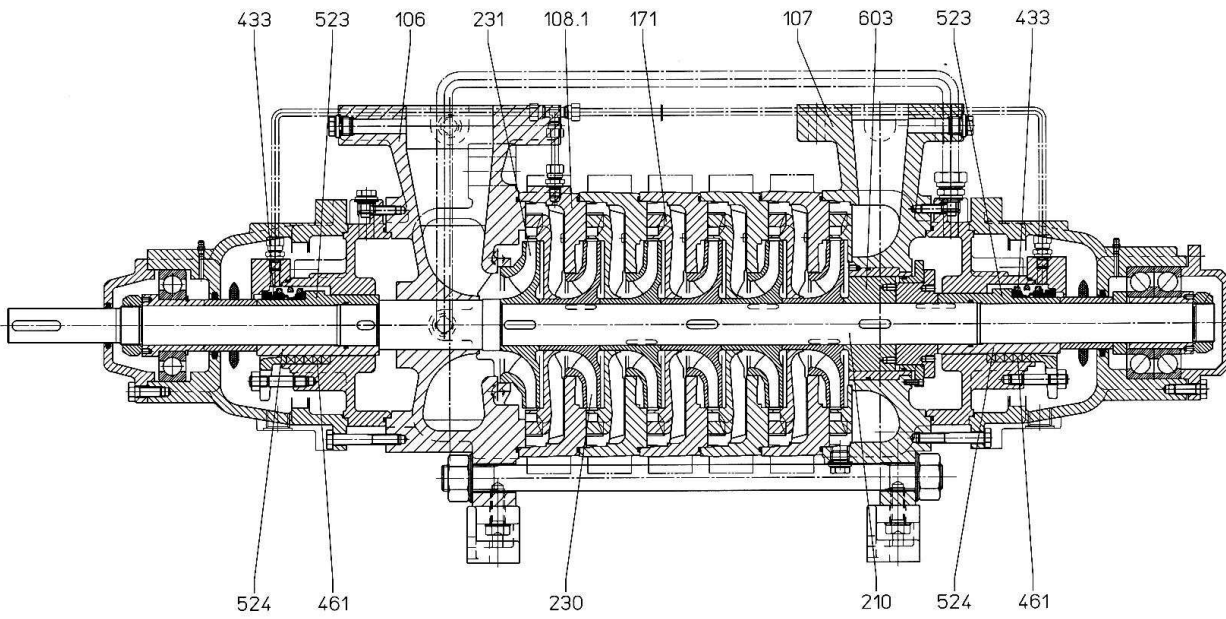

Sectional Drawing MSL, MSM with radial Inlet (drive on suction side)

Size 125

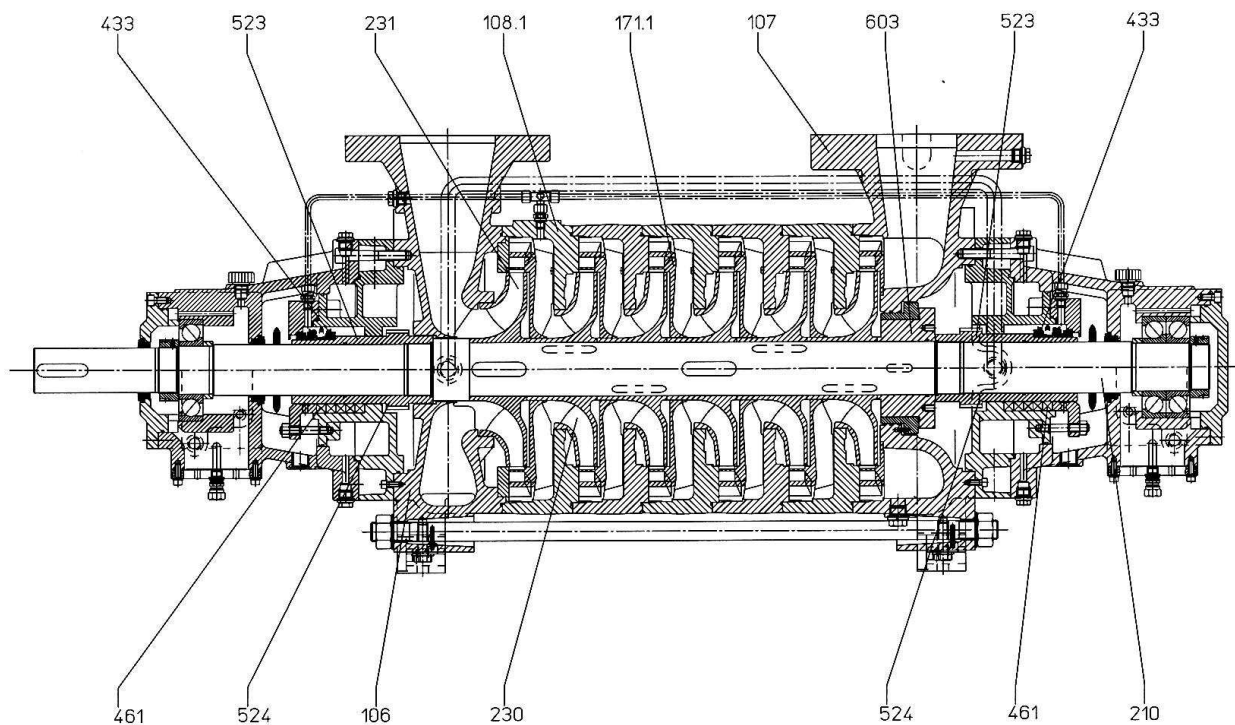

Size 150

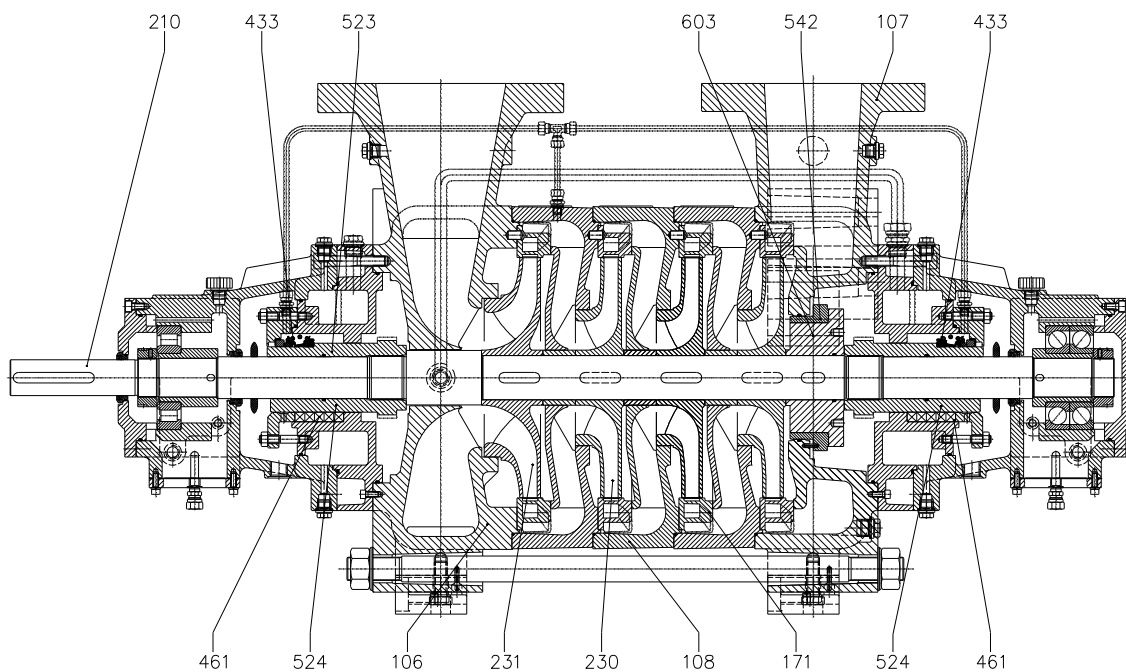

Material Design

Type MSL

Pos.	Item	Material of Construction						
		OR	OS	OV	OU	1R	SC	4R
106	Suction Casing	GG-25 EN-GJL 250				GGG-40 EN-JS 1030		1.4408
107	Discharge Casing	GG-25 EN-GJL 250				GGG-40 EN-JS 1030		1.4408
108	Stage Casing	GG-25 EN-GJL 250				GGG-40 EN-JS 1030		1.4408
230	Impeller	GG-25 EN-GJL-HB 195	Bronze 2.1050		GG-25 EN-GJL-HB 195			1.4408
231	Suction Impeller	GG-25 EN-GJL-HB 195	1.4409			GG-25 EN-GJL-HB 195	1.4408	1.4408
171	Diffuser	GG-25 EN-GJL-HB 195		Bronze 2.1050	GG-25 EN-GJL-HB 195			1.4408
210	Shaft	1.4021						1.4462
524	Shaft Protection Sleeve	1.4122						1.4460
523	Shaft Sleeve	1.4571						
603.1	Balance Drum System							
603.2		1.4122						1.4460
542.1	Throttle Bush	1.4021						1.4462
542.2	Throttle Bush	1.4088						
433	Mechanical Seal	various Material Options						
461	Packed Gland	various Material Options						

Type MSM

Pos.	Item	Material of Construction									
		0X	SA	1S	1V	1R	TA	TB	TD	TE	TF
106	Suction Casing	GG-25 EN-GJL 250				GGG-40 EN-JS 1030	GG-25 EN-GJL 250		1.4008		
107	Discharge Casing	GGG-40 EN-JS 1030				1.4008					
108	Stage Casing	GGG-40 EN-JS 1030				1.4008					
230	Impeller	GG-25 EN-GJL-HB 195	Bronze 2.1050		GG-25 EN-GJL-HB 195					1.4409	
231	Suction Impeller	GG-25 EN-GJL-HB 195	1.4408			GG-25 EN-GJL-HB 195	1.4408	GG-25 EN-GJL-HB 195	1.4408		
171	Diffuser	GG-25 EN-GJL-HB 195		Bronze 2.1050	GG-25 EN-GJL-HB 195					1.4408	
210	Shaft	1.4021									
524	Shaft Protection Sleeve	1.4122									
523	Shaft Sleeve	1.4571									
603.1	Balance Drum System										
603.2		1.4122									
542.1	Throttle Bush	1.4021									
542.2	Throttle Bush	1.4088									
433	Mechanical Seal	various Material Options									
461	Packed Gland	various Material Options									

Operating Limits

Allowable Casing Pressure, Test Pressure

Type MSL

Size	max. allowable Pressure (bar) as a function of Liquid Temperature ¹⁾																Test Pressure (bar)	
	material of construction																	
	Cast Iron						Ductile Iron				Stainless Steel							
	-10°C up to 120 °C		< 140°C		< 180 °C		-40°C up to 120°C		< 180°C		< 20°C up to 100°C		< 140 °C		< 180°C			
	S	D	S	D	S	D	S	D	S	D	S	D	S	D	S	D	S	D
032 up to 150	16	40	15	38	14	34	16	40	15	37	13	32	12	30	11	28	21	52

Type MSM

Size	max. allowable Pressure (bar) as a function of Liquid Temperature ¹⁾																Test Pressure (bar)			
	material of construction																			
	Cast Iron						Ductile Iron				Stainless Steel									
	-10°C up to 120 °C		< 140°C		< 180 °C		-10°C up to 120°C		< 140°C		< 180°C		-40°C up to 120 °C		< 140°C		< 180°C			
	S	D	S	D	S	D	S	D	S	D	S	D	S	D	S	D	S	D		
032 up to 150	16	63	15	58	14	56	16	63	15	62,5	14	60	16	63	15,7	62,5	15,5	60	21	82

¹⁾ consider mechanical seal pressure/temperature

S = suction casing, D = discharge casing

Max. Speed and Number of Stages

Type MSL

Size	Hydraulic	max. Speed rpm	max. Number of Stages
032	A	1450/1750	15
		2950	13
		3550	9
050	A, B	1450/1750	14
		2950	12
		3550	8
065	A, C	1450/1750	15
		2950	8
		3550	6
	B, D	1450/1750	13
		2950	6
		3550	4
100	A, C	1450/1750	10
		2950	3
		3550	2
	B, D	1450/1750	12
		2950	4
		3550	3
125	A, C	1450	11
		1750	8
		2950	3
	B, D	1450	12
		1750	10
		2950	3
150	A, C	1450	7
		1750	5
		3550	2
	B, D	1450	12
		1750	10
		2950	3
150	A, C	1450	7
		1750	5
		3550	2
B, D	1450	9	
	1750	6	
	3550	2	

Type MSM

Size	Hydraulic	max. Speed rpm	max. Number of Stages
032	A	1450/1750	18
		2950	18
		3550	13
	B	1450/1750	18
		2950	18
		3550	13
050	A, B	1450/1750	16
		2950	13
		3550	9
065	A, C	1450/1750	13
		2950	8
		3550	5
	B, D	1450/1750	16
		2950	10
		3550	7
100	A, C	1450/1750	16
		2950	5
		3550	3
	B, D	1450/1750	16
		2950	6
		3550	4
125	A, C	1450	12
		1750	12
		2950	4
	B, D	1450	12
		1750	12
		2950	5
150	A, C	1450	10
		1750	8
		3550	3
	B, D	1450	12
		1750	12
		2950	5
150	A, C	1450	10
		1750	8
		3550	3
B, D	1450	10	
	1750	8	
	3550	9	

Dimensional Drawing MSL with axial Inlet

Suction nozzle drilled to DIN EN 1092-2 or DIN 2543/2544 (PN16 or PN 25), ANSI B 16.1 or ANSI B 16.5 (250 FF or 300 RF)

Discharge nozzle drilled to DIN EN 1092-2 or DIN 2545 (PN 40), ANSI B 16.1 or ANSI B 16.5 (250 RF or 300 RF)

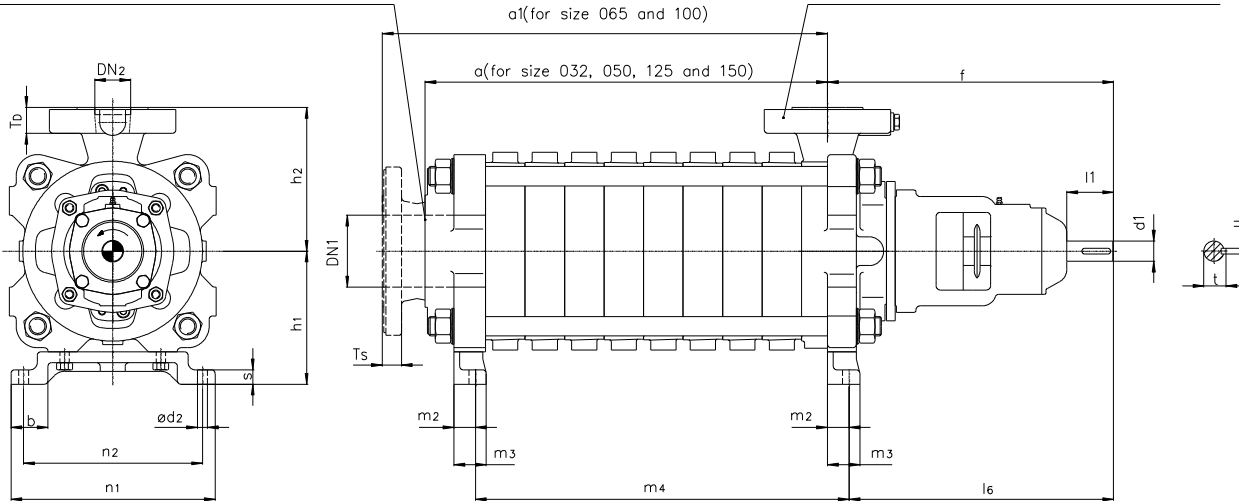

Drawing does not show all possible variants

Dimensions in mm, casing tolerance per DIN 1686/GBT 17 to be applied on dimensions of unmachined parts

Size	DN ₂	DN ₁	Pump dimensions					Feet dimensions								Shaft end			
			f	T _s	T _D	h ₁	h ₂	b	s	m ₂	m ₃	n ₁	n ₂	d ₂	l ₆	d ₁ ¹⁾	l ₁	t	u
032	032	080	410		24	165	175	70	20	30	45	335	300	14	380	28	60	31	8
050	050	100	415		36	185	200	70	20	30	45	335	300	14	385	28	60	31	8
065	065	125	510	38	39	230	250	88	25	35	60	380	320	19	490	40	110	43	12
100	100	150	520	37	33	285	320	88	25	35	60	380	320	19	485	40	110	43	12
125	125	150	649		51,5	320	365	97	30	40	75	410	350	24	609	70	166	74,5	20
150	150	200	660		39	365	450	115	30	70	110	490	410	30	660	55	167	59	16

Size	032		050		065		100		125		150	
	a	m ₄	a	m ₄	a ₁	m ₄	a ₁	m ₄	a	m ₄	a	m ₄
2	150	120	175	135	260	180	305	225	380	340	380	270
3	195	165	230	190	330	250	390	310	490	450	505	395
4	240	210	285	245	400	320	475	395	600	560	630	520
5	285	255	340	300	470	390	560	480	710	670	755	645
6	330	300	395	355	540	460	645	565	820	780	880	770
7	375	345	450	410	610	530	730	650	930	890	1005	895
8	420	390	505	465	680	600	815	735	1040	1000	1130	1020
9	465	435	560	520	750	670	900	820	1150	1110	1255	1145
10	510	480	615	575	820	740	985	905	1260	1220		
11	555	525	670	630	890	810	1070	990	1370	1330		
12	600	570	725	685	960	880	1155	1075	1480	1440		
13	645	615	780	740	1030	950	1240	1160				
14	690	660	835	795								
15	735	705	890	850								

¹⁾ k6 - tolerance fit

Dimensional Drawing MSL mit radial Inlet

Suction nozzle drilled to DIN EN 1092-2 or DIN 2543/2544 (PN16 or PN 25), ANSI B 16.1 or ANSI B 16.5 (250 FF or 300 RF)

Discharge nozzle drilled to DIN EN 1092-2 or DIN 2545 (PN 40), ANSI B 16.1 or ANSI B 16.5 (250 RF or 300 RF)

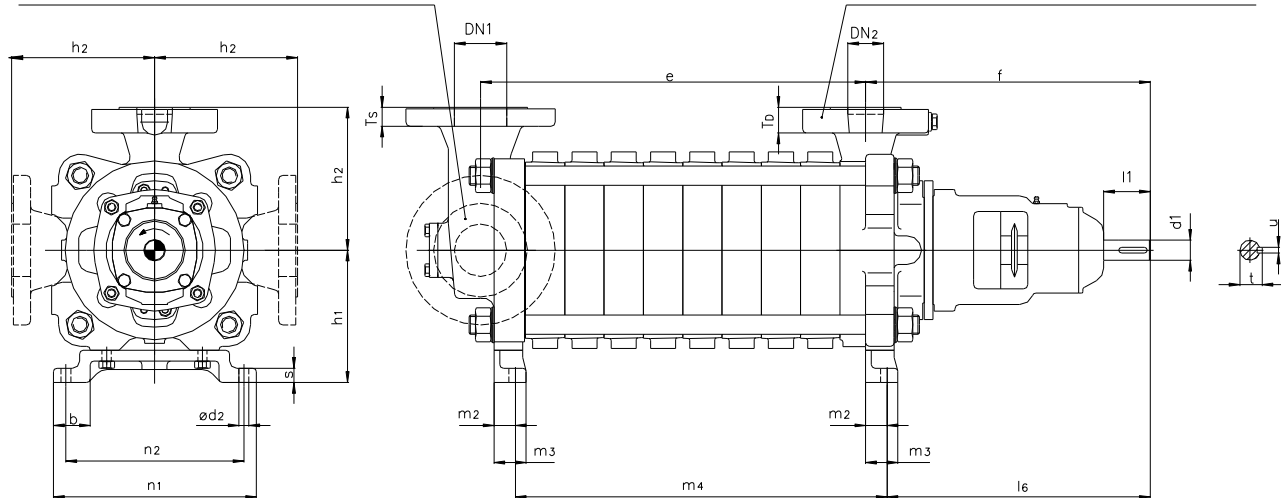

Drawing does not show all possible variants

Dimensions in mm, casing tolerance per DIN 1686/GTB 17 to be applied on dimensions of unmachined parts

Size	DN ₂	DN ₁	Pump dimensions					Feet dimensions							Shaft end				
			f	T _S	T _D	h ₁	h ₂	b	s	m ₂	m ₃	n ₁	n ₂	d ₂	l ₆	d ₁ ¹⁾	l ₁	t	u
032	032	050	410	23	24	165	175	70	20	30	45	335	300	14	380	28	60	31	8
050	050	080	415	32	36	185	200	70	20	30	45	335	300	14	385	28	60	31	8
065	065	100	510	36	39	230	250	88	25	35	60	380	320	19	490	40	110	43	12
100	100	125	520	35	33	285	320	88	25	35	60	380	320	19	485	40	110	43	12
125	125	150	649	36,5	51,5	320	365	97	30	40	75	410	350	24	609	70	166	74,5	20
150	150	200	660	41	39	365	450	115	30	70	110	490	410	30	660	55	167	59	16

Size	032		050		065		100		125		150	
Stages	e	m ₄	e	m ₄	e	m ₄	e	m ₄	e	m ₄	e	m ₄
2 ²⁾	115	120	155	135	215	180	265	225	295	375	325	325
3	160	165	210	190	285	250	350	310	405	485	450	450
4	205	210	265	245	355	320	435	395	515	595	575	575
5	250	255	320	300	425	390	520	480	625	705	700	700
6	295	300	375	355	495	460	605	565	735	815	825	825
7	340	345	430	410	565	530	690	650	845	925	950	950
8	385	390	485	465	635	600	775	735	955	1035	1075	1075
9	430	435	540	520	705	670	860	820	1065	1145	1200	1200
10	475	480	595	575	775	740	945	905	1175	1255		
11	520	525	650	630	845	810	1030	990	1285	1365		
12	565	570	705	685	915	880	1115	1075	1395	1475		
13	610	615	760	740	985	950						
14	655	660	815	795								
15	700	705	870	850								

¹⁾ k6 - tolerance fit

²⁾ Suction casing radial top only possible with 3 or more stages.

Dimensional Drawing MSM with axial Inlet

Suction nozzle drilled to DIN EN 1092-2 or DIN 2543/2544 (PN16 or PN 25), ANSI B 16.1 or ANSI B 16.5 (250 FF or 300 RF)

Discharge nozzle drilled to DIN EN 1092-2 or DIN 2546 (PN 63), ANSI B 16.5 (600 RF)

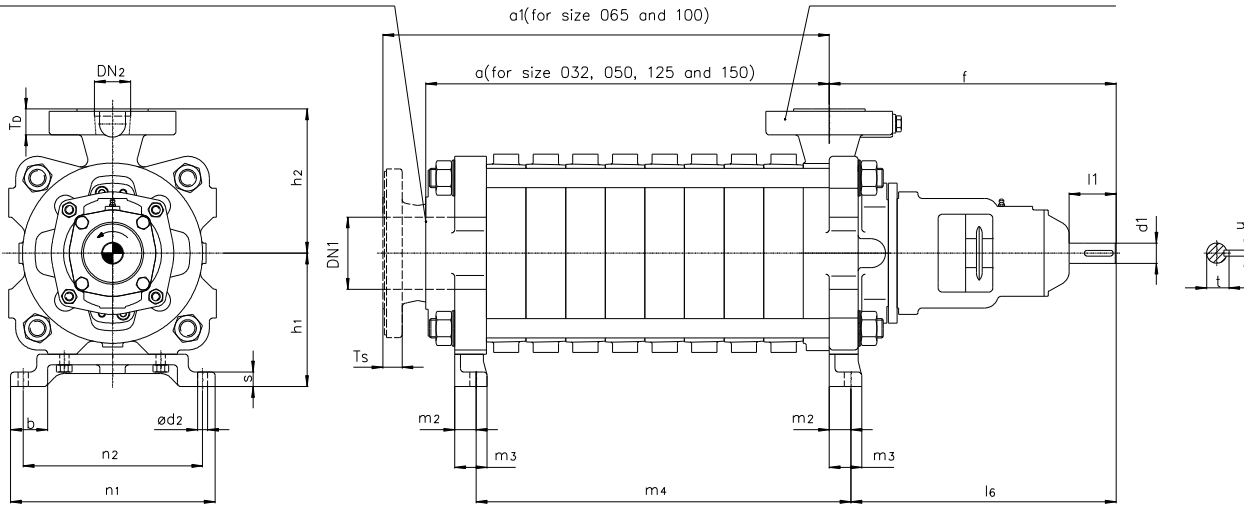

Drawing does not show all possible variants

Dimensions in mm, casing tolerance per DIN 1686/GTB 17 to be applied on dimensions of unmachined parts

Size	DN ₂	DN ₁	Pump dimensions					Feet dimensions								Shaft end			
			f	T _s	T _D	h ₁	h ₂	b	s	m ₂	m ₃	n ₁	n ₂	d ₂	l ₆	d ₁ ¹⁾	l ₁	t	u
032	032	080	410		24	165	175	70	20	30	45	335	300	14	380	28	60	31	8
050	050	100	415		36	185	200	70	20	30	45	335	300	14	385	28	60	31	8
065	065	125	510	38	39	230	250	88	25	35	60	380	320	19	490	40	110	43	12
100	100	150	520	37	33	285	320	88	25	35	60	380	320	19	485	40	110	43	12
125	125	150	649		51,5	320	365	97	30	40	75	410	350	24	609	70	166	74,5	20
150	150	200	660		39	365	450	115	30	70	110	490	410	30	660	55	167	59	16

Size	032		050		065		100		125		150	
	a	m ₄	a	m ₄	a ₁	m ₄	a ₁	m ₄	a	m ₄	a	m ₄
2	150	120	175	135	260	180	305	225	380	340	380	270
3	195	165	230	190	330	250	390	310	490	450	505	395
4	240	210	285	245	400	320	475	395	600	560	630	520
5	285	255	340	300	470	390	560	480	710	670	755	645
6	330	300	395	355	540	460	645	565	820	780	880	770
7	375	345	450	410	610	530	730	650	930	890	1005	895
8	420	390	505	465	680	600	815	735	1040	1000	1130	1020
9	465	435	560	520	750	670	900	820	1150	1110	1255	1145
10	510	480	615	575	820	740	985	905	1260	1220	1380	1270
11	555	525	670	630	890	810	1070	990	1370	1330		
12	600	570	725	685	960	880	1155	1075	1480	1440		
13	645	615	780	740	1030	950	1240	1160				
14	690	660	835	795	1100	1020	1325	1245				
15	735	705	890	850	1170	1090	1410	1330				
16	780	750	945	905	1240	1160	1495	1415				
17	825	795										
18	870	840										

¹⁾ k6 - tolerance fit

Dimensional Drawing MSM with radial Inlet

Suction nozzle drilled to DIN EN 1092-2 or DIN 2543/2544 (PN16 or PN 25), ANSI B 16.1 or ANSI B 16.5 (250 FF or 300 RF)

Discharge nozzle drilled to DIN EN 1092-2 or DIN 2546 (PN 63), ANSI B 16.5 (600 RF)

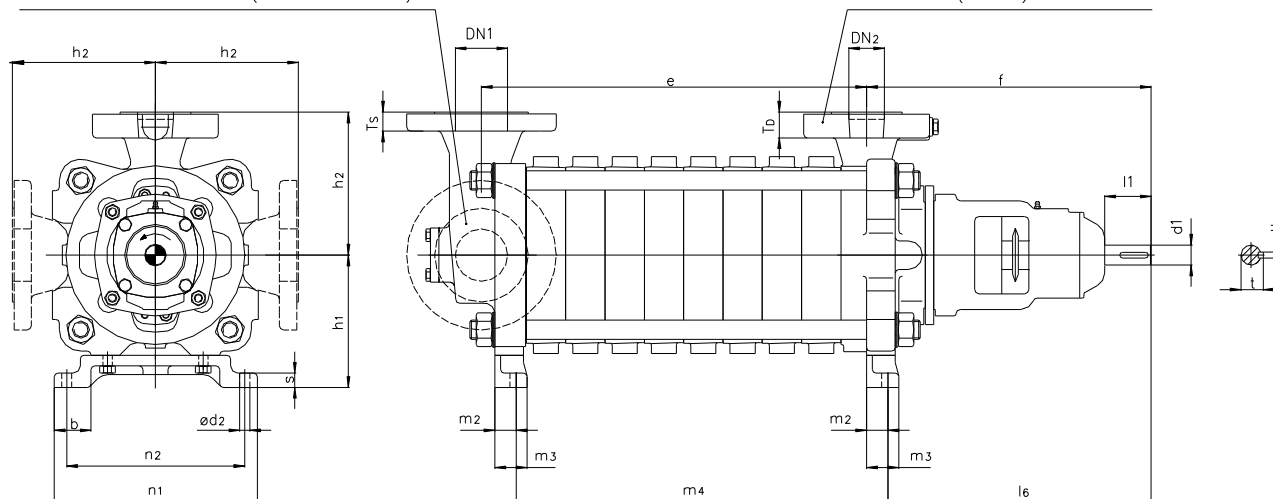

Drawing does not show all possible variants

Dimensions in mm, casing tolerance per DIN 1686/GBT 17 to be applied on dimensions of unmachined parts

Size	Pump dimensions		Feet dimensions													Shaft end			
	DN ₂	DN ₁	f	T _S	T _D	h ₁	h ₂	b	s	m ₂	m ₃	n ₁	n ₂	d ₂	l ₆	d ₁ ¹⁾	l ₁	t	u
032	032	050	410	23	24	165	175	70	20	30	45	335	300	14	380	28	60	31	8
050	050	080	415	32	36	185	200	70	20	30	45	335	300	14	385	28	60	31	8
065	065	100	510	36	39	230	250	88	25	35	60	380	320	19	490	40	110	43	12
100	100	125	520	35	33	285	320	88	25	35	60	380	320	19	485	40	110	43	12
125	125	200	649	36,5	51,5	320	365	97	30	40	75	410	350	24	609	70	166	74,5	20
150	150	200	660	41	39	365	450	115	30	70	110	490	410	30	660	55	167	59	16

Size	032		050		065		100		125		150	
Stages	e	m ₄	e	m ₄	e	m ₄	e	m ₄	e	m ₄	e	m ₄
2 ²⁾	115	120	155	135	215	180	265	225	295	375	325	325
3	160	165	210	190	285	250	350	310	405	485	450	450
4	205	210	265	245	355	320	435	395	515	595	575	575
5	250	255	320	300	425	390	520	480	625	705	700	700
6	295	300	375	355	495	460	605	565	735	815	825	825
7	340	345	430	410	565	530	690	650	845	925	950	950
8	385	390	485	465	635	600	775	735	955	1035	1075	1075
9	430	435	540	520	705	670	860	820	1065	1145	1200	1200
10	475	480	595	575	775	740	945	905	1175	1255	1325	1325
11	520	525	650	630	845	810	1030	990	1285	1365	1450	1450
12	565	570	705	685	915	880	1115	1075	1395	1475	1575	1575
13	610	615	760	740	985	950	1200	1160				
14	655	660	815	795	1055	1020	1285	1245				
15	700	705	870	850	1125	1090	1370	1330				
16	745	750	925	905	1195	1160	1455	1415				
17	790	795										
18	835	840										

¹⁾ k6 - tolerance fit

²⁾ Suction casing radial top only possible with 3 and more stages.

Dimensional Drawing MSL and MSM with radial Inlet (drive on suction side)

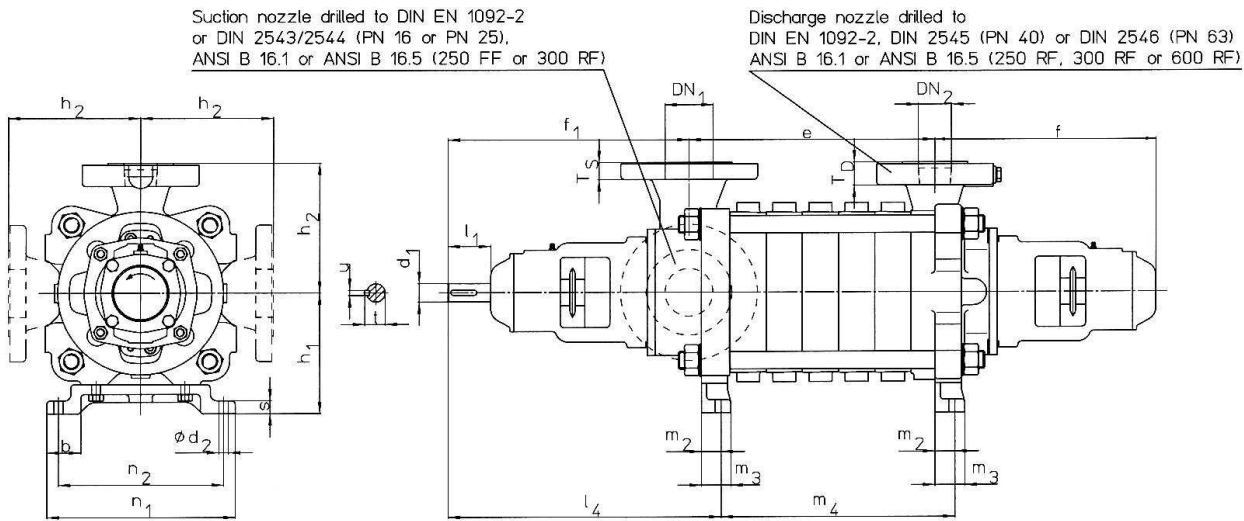

Drawing does not show all possible variants

Dimensions in mm, casing tolerance per DIN 1686/GTB 17 to be applied on dimensions of unmachined parts

Size	Pump dimensions		Feet dimensions													Shaft end				
	DN ₂	DN ₁	f	f ₁	T _S	T _D	h ₁	h ₂	b	s	m ₂	m ₃	n ₁	n ₂	d ₂	l ₄	d ₁ ¹⁾	l ₁	t	u
032	032	050	350	390	23	24	165	175	70	20	30	45	335	300	14	415	28	60	31	8
050	050	080	355	410	32	36	185	200	70	20	30	45	335	300	14	460	28	60	31	8
065	065	100	397	504	36	39	230	250	88	25	35	60	380	320	19	559	40	110	43	12
100	100	125	410	501	35	33	365	450	88	25	35	110	380	320	19	471	40	113	43	12
125 ³⁾	125	150	483	644	36,5	51,5	320	365	97	30	40	75	410	350	24	604	70	166	74,5	20
150 ³⁾	150	200	493	655	41	39	365	450	115	30	40	110	490	410	30	655	55	167	59	16

Size	032		050		065		100		125		150	
Stages	e	m ₄	e	m ₄	e	m ₄	e	m ₄	e	m ₄	e	m ₄
2 ²⁾	115	120	155	135	215	180	265	330	295	375	325	325
3	160	165	210	190	285	250	350	415	405	485	450	450
4	205	210	265	245	355	320	435	500	515	595	575	575
5	250	255	320	300	425	390	520	585	625	705	700	700
6	295	300	375	355	495	460	605	670	735	815	825	825
7	340	345	430	410	565	530	690	755	845	925	950	950
8	385	390	485	465	635	600	775	840	955	1035	1075	1075
9	430	435	540	520	705	670	860	925	1065	1145	1200	1200
10	475	480	595	575	775	740	945	1010	1175	1255	1325	1325
11	520	525	650	630	845	810	1030	1095	1285	1365		
12	565	570	705	685	915	880	1115	1180	1395	1475		
13	610	615	760	740	985	950	1200	1265				
14	655	660	815	795	1055	1020	1285	1350				
15	700	705	870	850	1125	1090	1370	1435				
16	745	750	925	905	1195	1160	1455	1520				
17	790	795										
18	835	840										

¹⁾ k6 - tolerance fit

²⁾ Suction casing radial top only possible with 3 and more stages.

³⁾ with oil lubrication

Connections

MSL with axial Inlet (Size 032 up to 100)

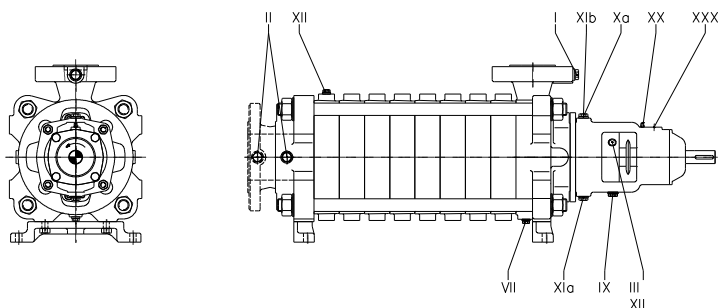

Pos.	Connection	Size Dimension	
		032 050	065 100
I ¹⁾	Pressure gauge	G1/2	G1/2
II ¹⁾	Pressure gauge	G1/2	G1/2
III ¹⁾	Vent	G1/4	G1/4
VII ¹⁾	Drain	G1/4	G1/2
IX ¹⁾	Drain	G3/8	G3/4
Xa	Flushing connection	G1/4	G1/4
XIa	Cooling inlet seal chamber	G3/8	G1/2
XIb	Cooling outlet seal chamber	G3/8	G1/2
XII	Connection for circulation	G1/4	G1/4
XX	Grease luibrication	M6	M6
XXX	Thrust impulse measuring possible		

¹⁾ tapped and plugged

MSL with radial Inlet (Size 032 up to 100)

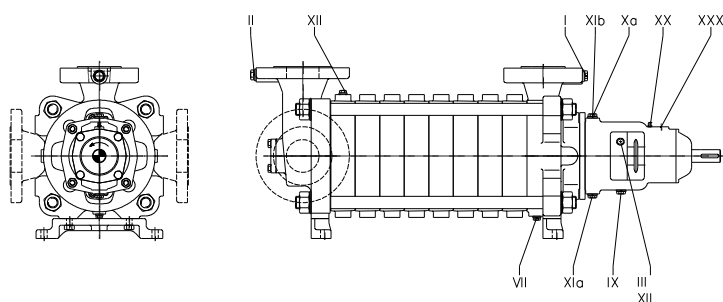

MSM with axial Inlet (Size 032 up to 100)

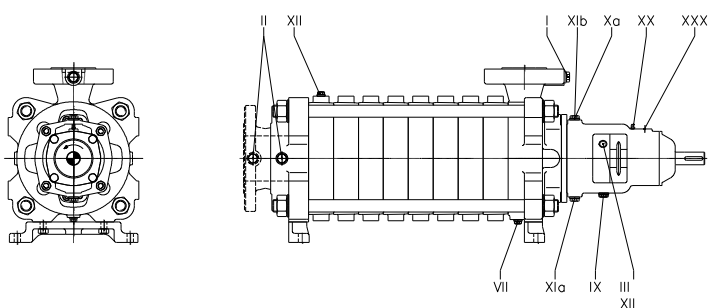

Pos.	Connection	Size Dimension	
		032 050	065 100
I ¹⁾	Pressure Gauge	G1/2	G1/2
II ¹⁾	Pressure Gauge	G1/2	G1/2
III ¹⁾	Vent	G1/4	G1/4
VII ¹⁾	Drain	G1/4	G1/2
IX ¹⁾	Drain	G3/8	G3/4
XIa	Cooling Inlet - seal chamber	G3/8	G1/2
XIb	Cooling Outlet - seal chamber	G3/8	G1/2
XII	Connection for Circulation	G1/4	G1/4
XX	Grease Luibrication	M6	M6
XXX	Thrust Impulse Measuring possible		

¹⁾ tapped and plugged

MSM with radial Inlet (Size 032 up to 100)

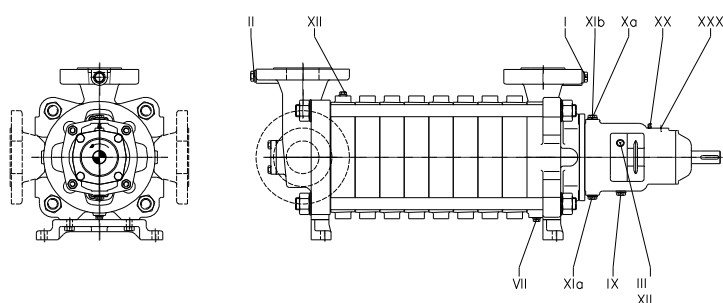

Connections

MSL/MSM with axial Inlet (Size 125 and 150)

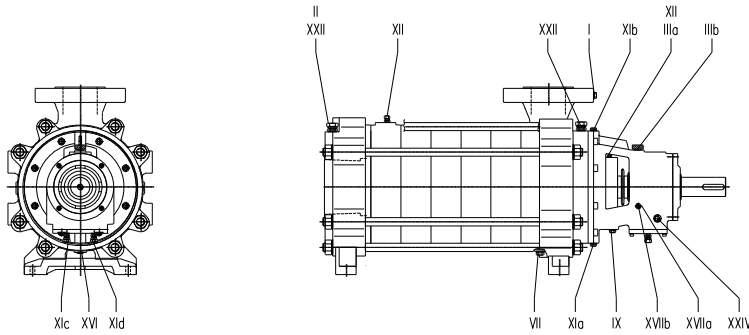

MSL/MSM with radial Inlet (Size 125 and 150)

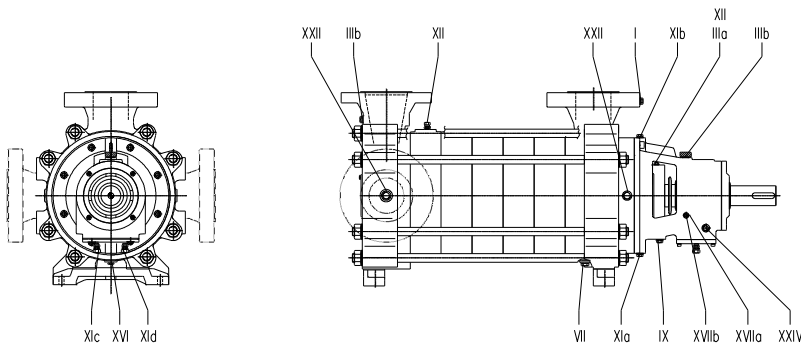

MSL/MSM with drive end on suction side (Size 125 and 150)

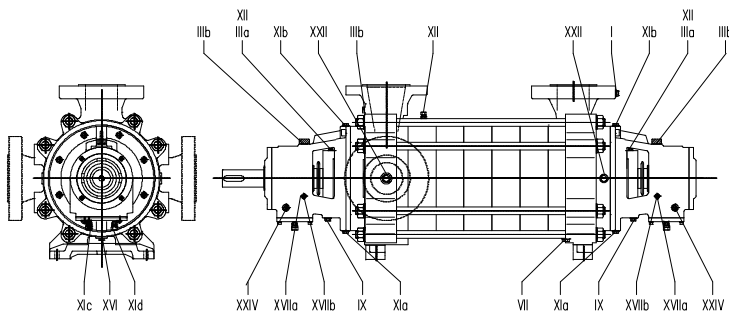

Pos.	Connection	Size Dimension	
		125	150
I ¹⁾	Pressure gauge	G1/2	G1/2
IIa ¹⁾	Pressure gauge	G1/2	G1/2
IIIa	Vent mechanical seal	G1/2	G1/2
IIIb	Vent bearing	G1/2	G1/2
VII ¹⁾	Drain	G3/4	G3/4
IX ¹⁾	Leck outlet	G1/2	G1/2
XIa	Cooling inlet seal chamber	G1/2	G1/2
XIb	Cooling outlet seal chamber	G1/2	G1/2
XIc	Cooling inlet bearing	Pipe ø 12	Pipe ø 12
XId	Cooling outlet bearing	Pipe ø 12	Pipe ø 12
XII	Connection for circulation	G1/4	G1/4
XVI ¹⁾	Oil outlet	G3/8	G3/8
XVIIa	Oil level sight glas	G1/2	G1/2
XVIIb	Constant level oiler	G1/4	G1/4
XXII	Connection for balancing flow	G3/4	G3/4
XXIV ¹⁾	Connection for thermometer	G1/2	G1/2

¹⁾ tapped and plugged

Material Description

Material-No.	Manufacturing standard			equivalent or comparable standard				components
	DIN-material code		EN-designation	US-material code		ISO	Japan JIS	
	old	new		ASTM-Standards	UNS			
EN-JL 1040	GG-25	EN-GJL 250	EN-GJL 250	A 278 Class 30	F 12401	185/Gr. 250	G 5501, FC 300	Casing
EN-JL 2030	GG-25	EN-GJL-HB 195	EN-GJL-HB 195	A 48 Class 25/30	F 11701/F 12101	185/Gr. 300	G 5501, FC 250/300	Impeller/Diffuser
EN-JS 1030	GGG-40	EN-GJS-400-15	EN-GJS-400-15	A 536 Gr. 60-40-18				Casing
2.1050	G-CuSn 10			B 427 C91600	C 91600			Impeller/Diffuser
1.4008	G-X8CrNi 13	G-X7CrNiMo 12-1	G-X7CrNiMo 12-1	A 217 Gr. CA 15	J 91 150		G 5121, C1 SCS 1	Casing
1.4088		G-X170Cr18	G-X170Cr18					Throttle Bush
1.4021	X20Cr 13	X20Cr 13	X20Cr 13	A 276 Type 420	S 42 000	683-13-4	G 4303, Gr1 SUS 403	Shaft, Throttle Bush
1.4122	X35CrMo 17	X39CrMo 17-1	X39CrMo 17-1					Balance Drum, Shaft Sleeve
1.4408	G-X6CrNiMo 18 10	G-X5CrNiMo 19-11-2	G-X5CrNiMo 19-121-2	A 351, 743, 744 CF 8M	J 92 800	683-13-9	SCS 14	Impeller/Diffuser, Casing
1.4460	X4CrNiMo 27 5 2	X3CrNiMoN 27-5-2	X3CrNiMoN 27-5-2					Balance Drum
1.4462	X2CrNiMoN 22 5 3	X2CrNiMoN 22-5-3	X2CrNiMoN 22-5-3	A 276-S 31803	S 31 803		G 4303, Gr1 SUS 329	Shaft, Throttle Bush
1.4571	X6CrNiMoTi 17 12 2	X6CrNiMoTi 17-12-2	X6CrNiMoTi 17-12-2	193 Gr. B 8 M	S 31 600	683-1-21	G 4303, Gr1 SUS 316	Shaft Sleeve

Materials are produced to EN/DIN specifications. For other equivalent or comparable standards are mentioned only for information.

ASTM American Society for Testing and Materials
 DIN Deutsches Institut für Normung e.V.
 EN European Standard
 ISO International Standardisation Organisation
 UNS Unified Numbering System (USA)

Supplied by
Prime Fluid Management
0800 482 747 | info@primefluid.co.nz | primefluid.co.nz

Sterling SIHI GmbH
Werk Ludwigshafen
Halbergstr. 1, D-67061 Ludwigshafen, Germany
Telefon +49 (0)621 56 12 - 0 Telefax +49 (0)621 56 12 - 209