



---

# Submersible Stirrer

MX19

---



# Submersible Stirrer MX19



## Construction features

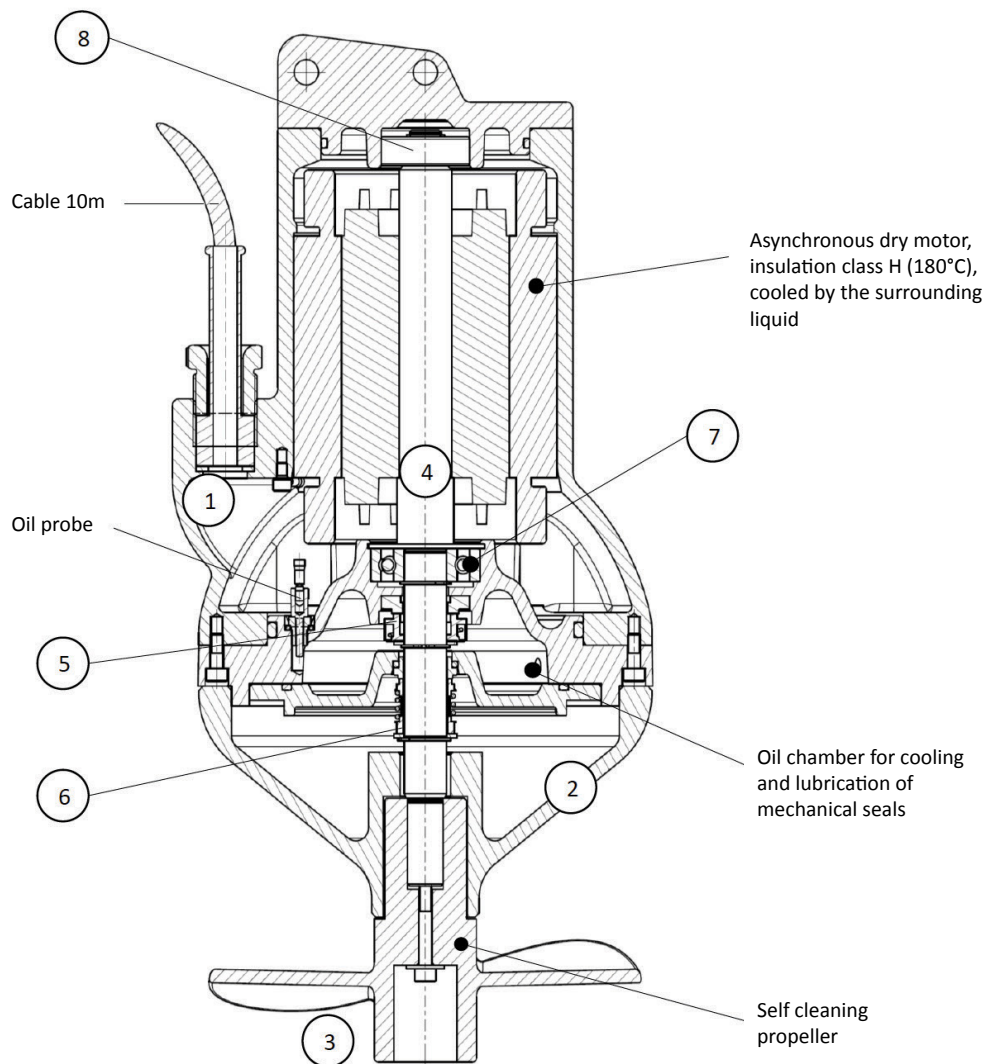

| No. | Description             | Material  |
|-----|-------------------------|-----------|
| 1   | Motor                   | Cast iron |
| 2   | Cover                   | Cast iron |
| 3   | Self cleaning propeller | AISI 316L |
| 4   | Shaft                   | AISI 420B |

| No. | Description      | Material            |
|-----|------------------|---------------------|
| 5   | Upper mech. seal | Carbon/Graphite/NBR |
| 6   | Lower mech. seal | SiC/SiC/NBR         |
| 7   | Top bearing      | 6302 2RS            |
| 8   | Lower bearing    | 6304 2RS            |

# Submersible Stirrer

## MX19



### Influence area

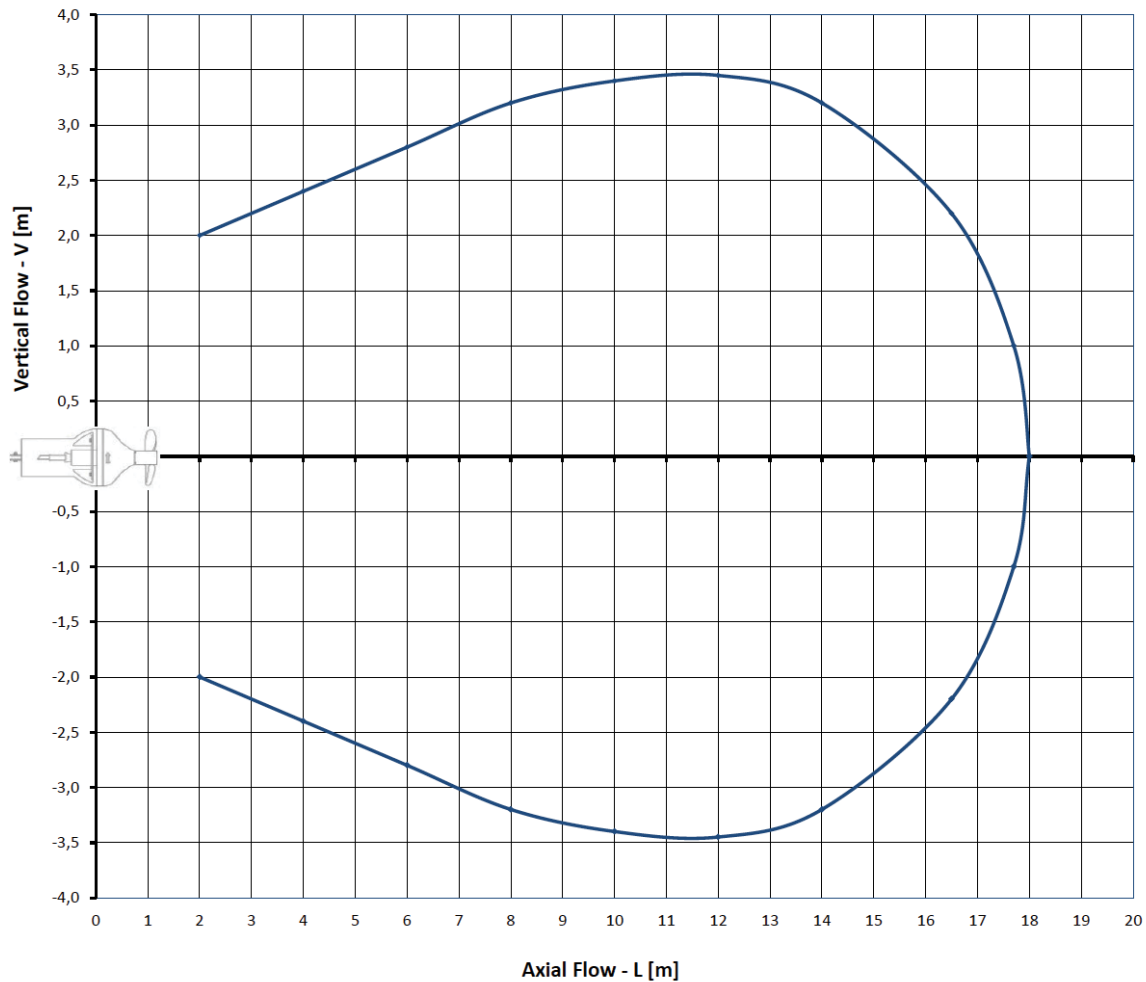

|                |   |     |     |     |     |      |      |      |      |      |  |  |  |
|----------------|---|-----|-----|-----|-----|------|------|------|------|------|--|--|--|
| Axial Flow (L) | m | 2,0 | 4,0 | 6,0 | 8,0 | 10,0 | 12,0 | 14,0 | 16,5 | 18,0 |  |  |  |
| Vert. Flow (V) | m | 4,0 | 4,8 | 5,6 | 6,4 | 6,8  | 6,9  | 6,4  | 4,4  | 0,0  |  |  |  |

### Specifications

|                    |  |                    |                |                 |      |
|--------------------|--|--------------------|----------------|-----------------|------|
| Stirrer Type       | MX19   | Guide Bar          | 60x60          | Humidity Probe  | Yes  |
| Code               | MX19T2.142R*                                   | Power Supply       | 3ph 400 - 50Hz | Cable Length    | 10m  |
| Construction       | Cast Iron with 316 S/S Self Cleaning Propellor | Nominal Speed      | 1450rpm        | Ingress Rating  | IP68 |
| Propeller Diameter | 210mm  | Rated Motor Power  | 2.1kW          | * R: Rear mount |      |
| Weight             | 40kg   | Starting Current   | 16A            |                 |      |
| Blade Number       | 2  | Rated Current      | 4.2A           |                 |      |
| Reaction Thrust    | 250N   | Thermal Protection | Yes            |                 |      |

# Submersible Stirrer

## MX19



### Dimensions and installation

#### S Installation mobile

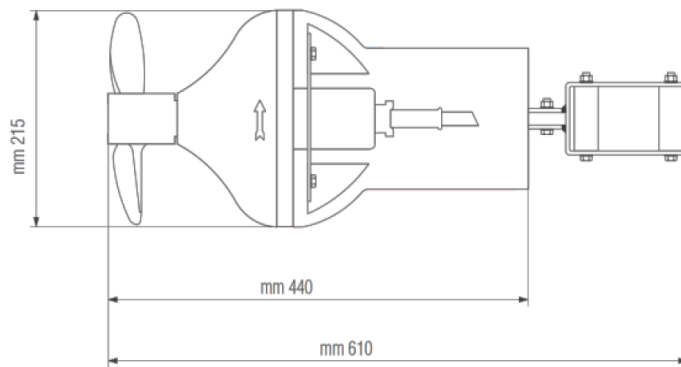

|                    |     |
|--------------------|-----|
|                    | mm  |
| Propeller diameter | 210 |

#### Packaging dimensions

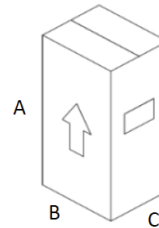

#### Measures [mm]

| A   | B   | C   |
|-----|-----|-----|
| 720 | 370 | 300 |

#### FC Installation

SYSTEM LDV 2"  
8LDV000003

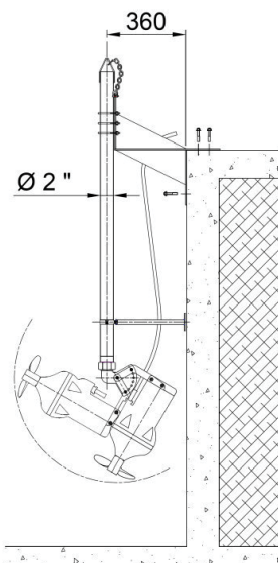

SYSTEM LDV 60 ECO  
8LDV000002

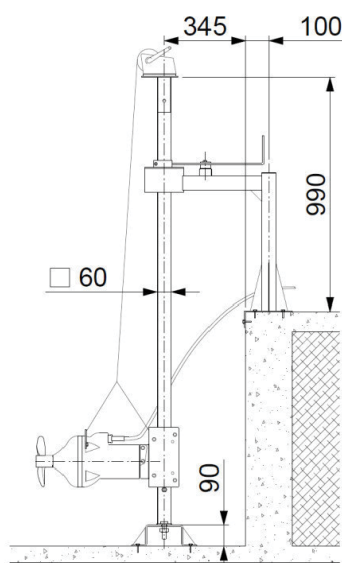

SYSTEM LDV 60  
8LDV000001

