 **SolidsPro**

Vortex Submersible Pump

VX50T322



Vortex Submersible Pump

VX50T322



Construction features

Asynchronous dry motor, insulation class F(155°C), cooled by the surrounding liquid

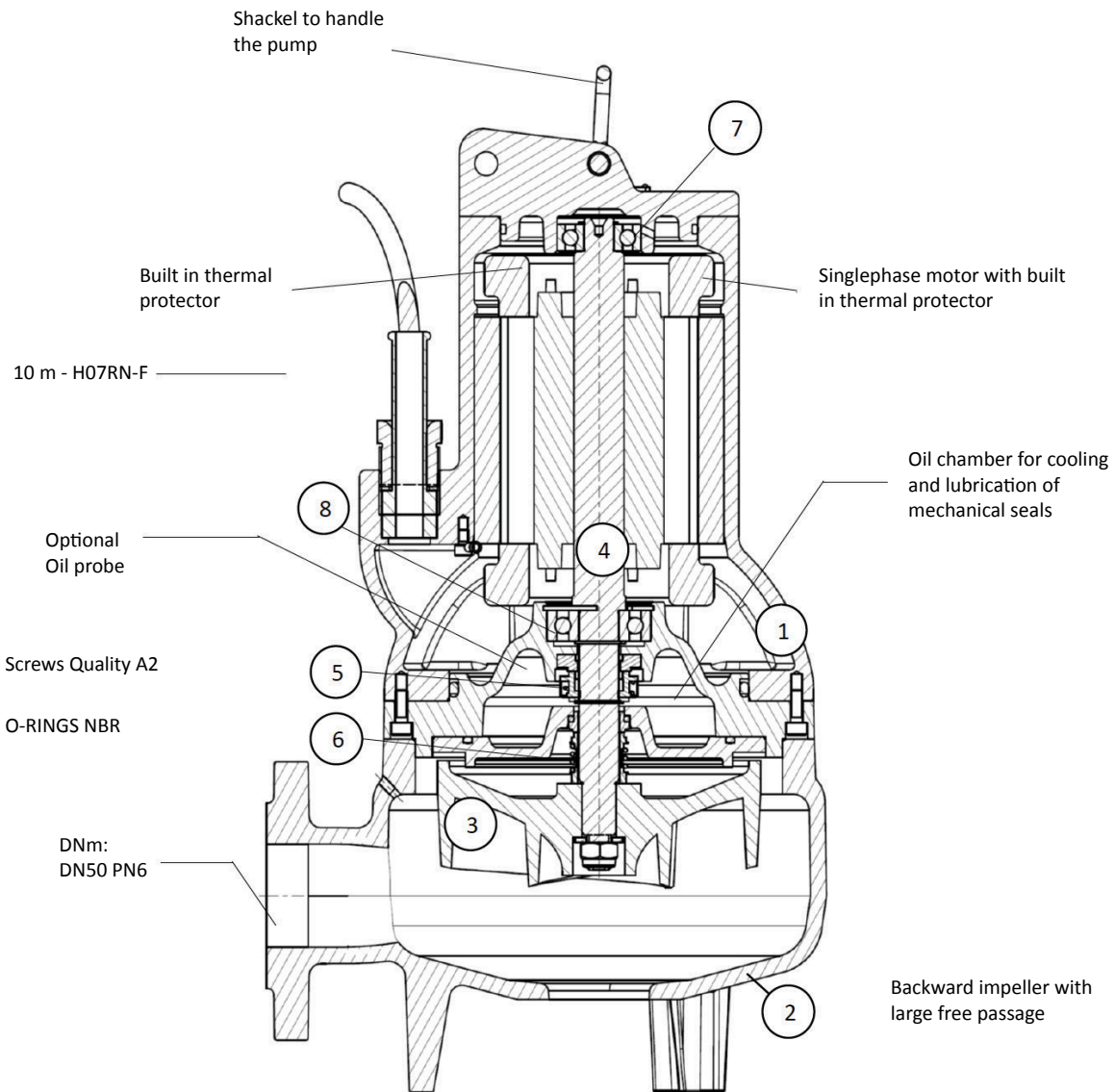

No.	Description	Material
1	Motor group	Cast iron
2	Cover	Cast iron
3	Self cleaning propeller	Cast iron
4	Shaft	AISI 420B

No.	Description	Material
5	Upper mech. seal	Carbon/Graphite/NBR
6	Lower mech. seal	SiC/SiC/NBR
7	Top bearing	6302-2RS
8	Lower bearing	6304-2RS

Vortex Submersible Pump

VX50T322



PERFORMANCE CURVE

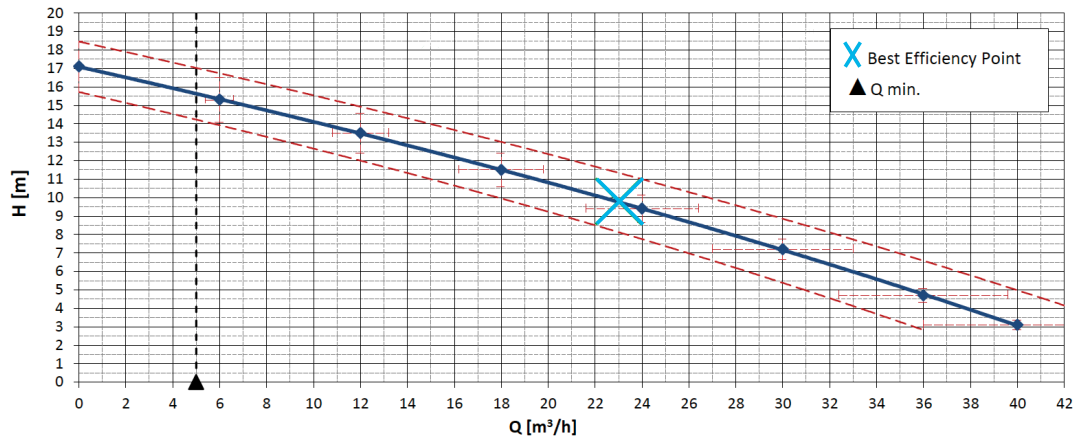

SHAFT POWER

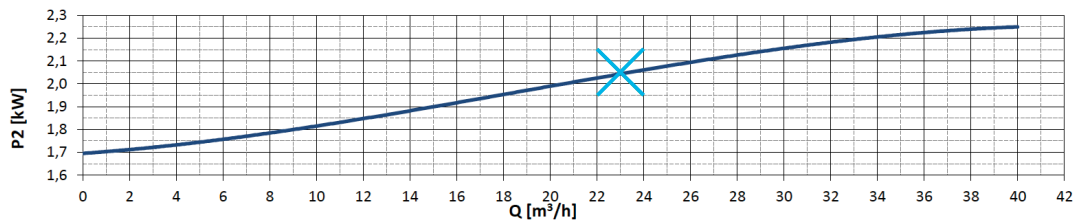

HYDRAULIC EFFICIENCY

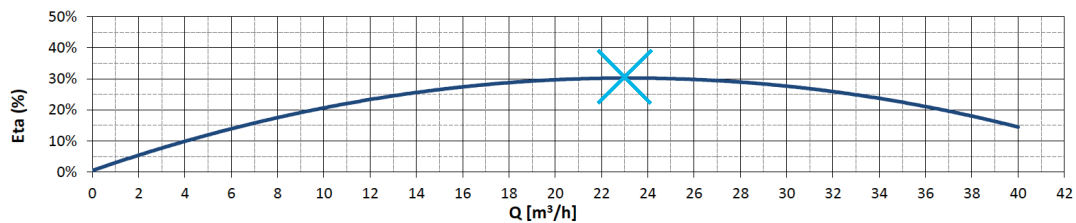

FLOW (Q)	l/min	0,0	100,0	200,0	300,0	400,0	500,0	600,0	666,7				
	l/s	0,0	1,7	3,3	5,0	6,7	8,3	10,0	11,1				
	m ³ /h	0,0	6,0	12,0	18,0	24,0	30,0	36,0	40,0				
HEAD (H)	m	17,1	15,3	13,5	11,5	9,4	7,2	4,7	3,1				

Specifications

Pump Type	VX50T	Discharge	50mm BSP	Humidity Probe	Yes
Code	VX50T322	Power Supply	3ph 400V - 50Hz	Cable Length	10m
Construction	Cast Iron	Nominal Speed	2900rpm	Max Flow	40m ³ /hr
Impeller Type	Vortex	Rated Motor Power	3kW	Max Head	17.1m
Weight	36kg	Starting Current	24.2A	Ingress Rating	IP68
Impeller diameter	162mm	Rated Current	5.5A		
Solids Passage	48mm	Thermal Protection	Yes		

Vortex Submersible Pump

VX50T322



Dimensions and installation

S Installation mobile

Packaging dimensions

Measures [mm]

A	B	C
600	240	290

FC With foot coupling

8FC000002

1	3/4" guide rails bracket
2	Horizontal foot - 2"out
3	Sliding bracket complete
4	Not supplied

D

D	260mm
E	175mm
F	195mm