



# Vortex Submersible Pump

VX65T2.242

---



# Vortex Submersible Pump

VX65T2.242



## Construction features

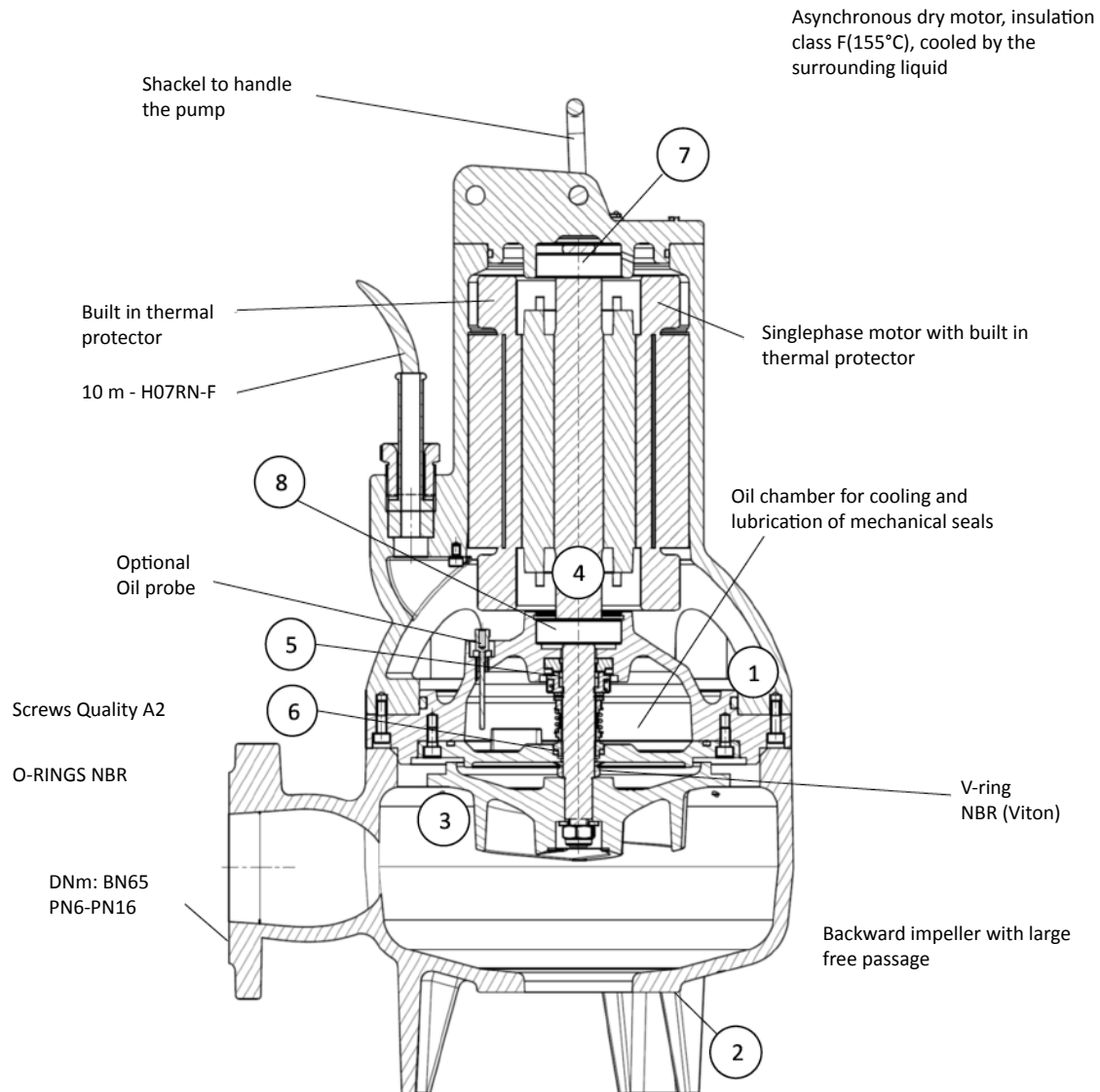

No.	Description	Material
1	Motor group	Cast iron
2	Cover	Cast iron
3	Self cleaning propeller	Cast iron
4	Shaft	AISI 420B

No.	Description	Material
5	Upper mech. seal	Carbon/Graphite/NBR
6	Lower mech. seal	SiC/SiC/NBR
7	Top bearing	6302-2RS
8	Lower bearing	6304-2RS

# Vortex Submersible Pump VX65T2.242



### PERFORMANCE CURVE

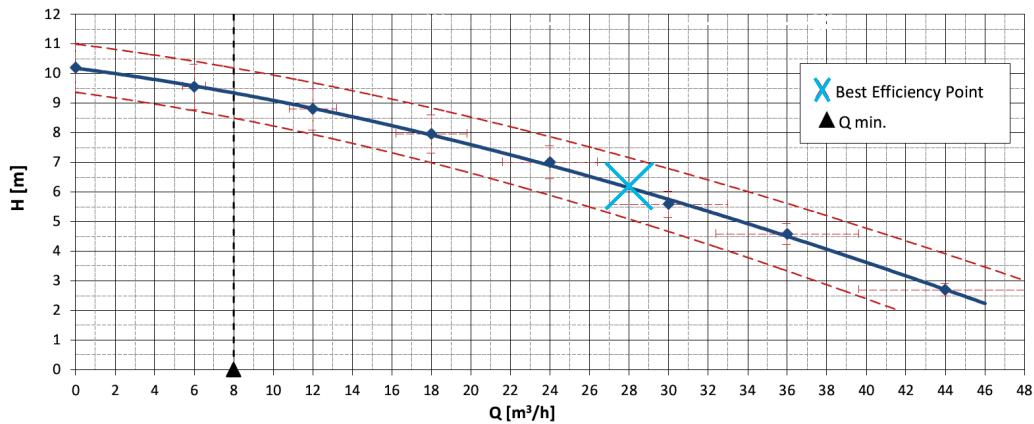

### SHAFT POWER

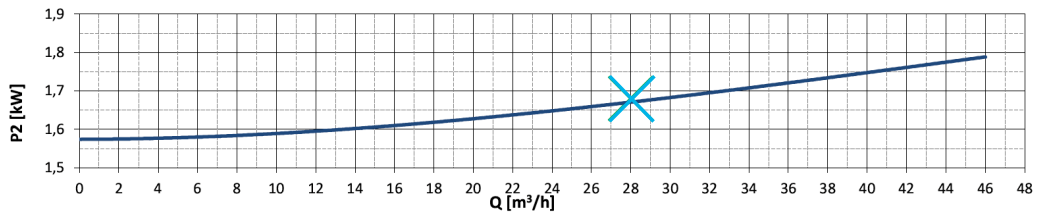

### HYDRAULIC EFFICIENCY

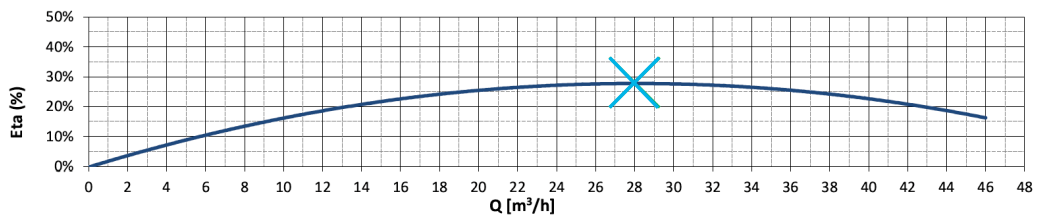

	l/min	0,0	100,0	200,0	300,0	400,0	500,0	600,0	733,3				
FLOW (Q)	l/s	0,0	1,7	3,3	5,0	6,7	8,3	10,0	12,2				
	m³/h	0,0	6,0	12,0	18,0	24,0	30,0	36,0	44,0				
HEAD (H)	m	10,2	9,6	8,8	8,0	7,0	5,6	4,6	2,7				

## Specifications

Pump Type	VX65T	Discharge	65mm BSP	Humidity Probe	Yes
Code	VX65T2.242	Power Supply	3ph 400V - 50Hz	Cable Length	10m
Construction	Cast Iron	Nominal Speed	1450rpm	Max Flow	44m3/hr
Impeller Type	Vortex	Rated Motor Power	2.2kW	Max Head	10.2m
Weight	62kg	Starting Current	21A	Ingress Rating	IP68
Impeller diameter	190mm	Rated Current	4.4A		
Solids Passage	65mm	Thermal Protection	Yes		

# Vortex Submersible Pump

VX65T2.242



## Dimensions and installation

**S Installation mobile**

UNI EN 1092-1 DN65  
 PN6 Ø130 4XØ14  
 PN16 Ø145 4XØ18

**Packaging dimensions**

**Measures [mm]**

A	B	C
720	370	300

**FC With foot coupling**

REF. 80 475 264  
 S1  
 Ø26,9 sp.2  
 Ø3/4"  
 S3 15%  
 G 2"1/2  
 171 599 279 95  
 67 2XR6,5 55 38  
 Ø260 100 4xØ14  
 110

**8FC00003 KG: 10**

1	3/4" guide rails bracket
2	Horizontal foot - 2"1/2 out
3	Sliding bracket complete
4	Not supplied

**D 260**  
**E 175**  
**F 195**