



Vortex Submersible Pump

VX80T4.942



Vortex Submersible Pump

VX80T4.942



Construction features

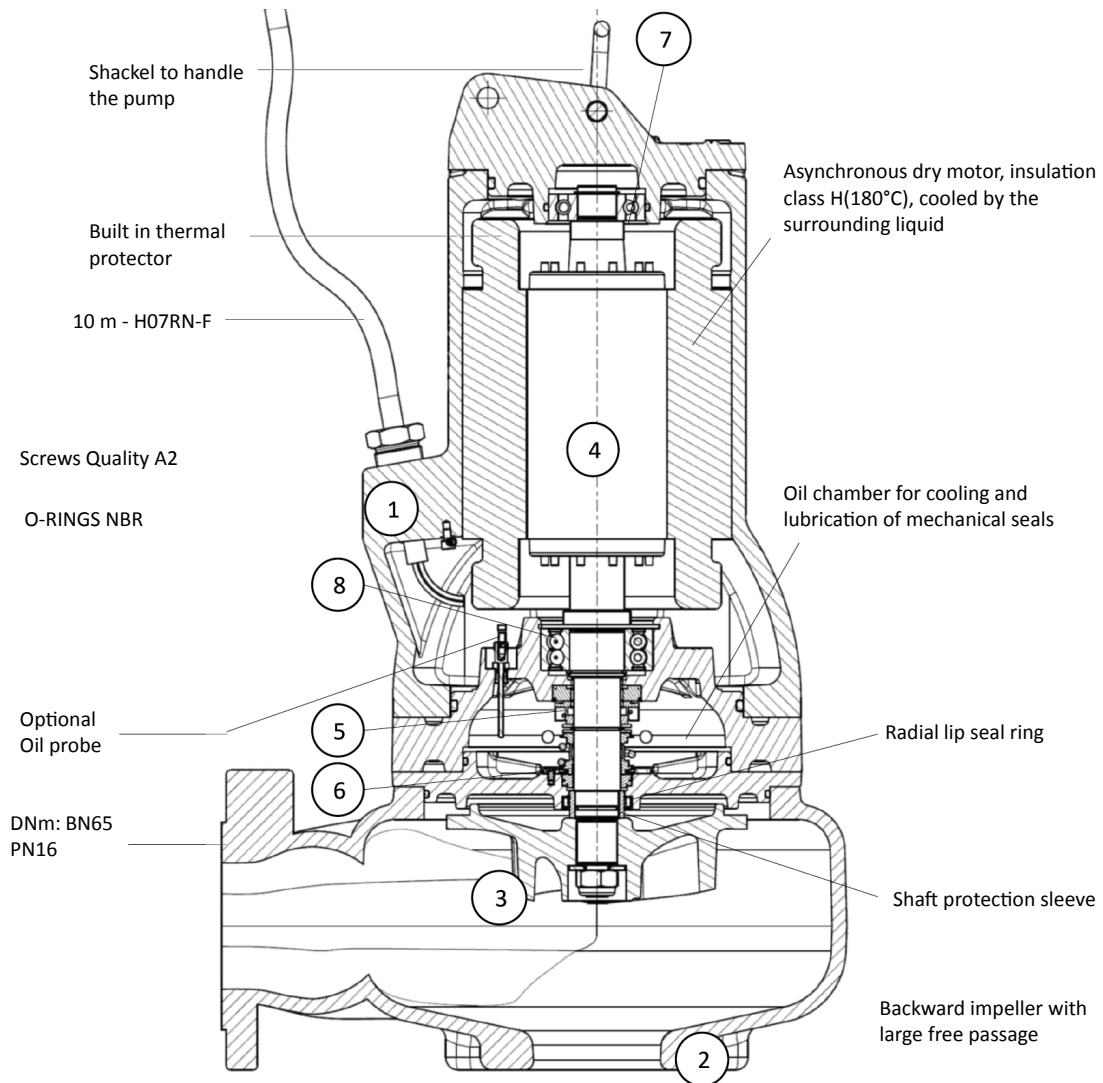

No.	Description	Material
1	Motor group	Cast iron
2	Cover	Cast iron
3	Self cleaning propeller	Cast iron
4	Shaft	AISI 420B

No.	Description	Material
5	Upper mech. seal	Carbon/Graphite/NBR
6	Lower mech. seal	SiC/SiC/NBR
7	Top bearing	6305-2RS
8	Lower bearing	3207-2RS

Vortex Submersible Pump

VX80T4.942

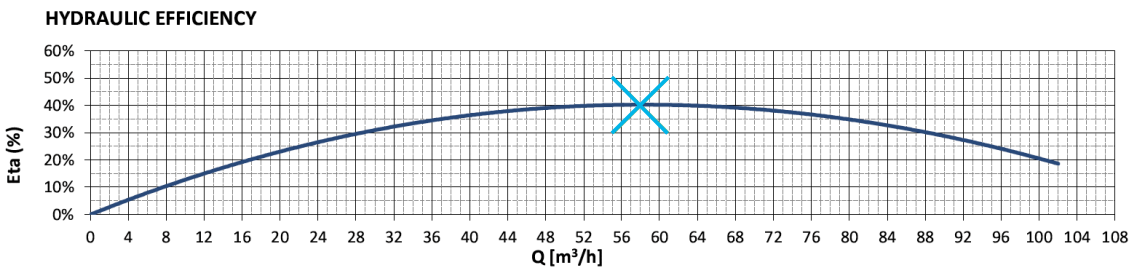
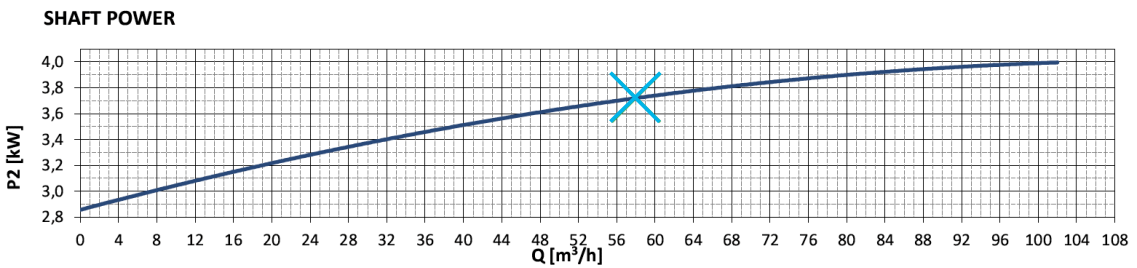
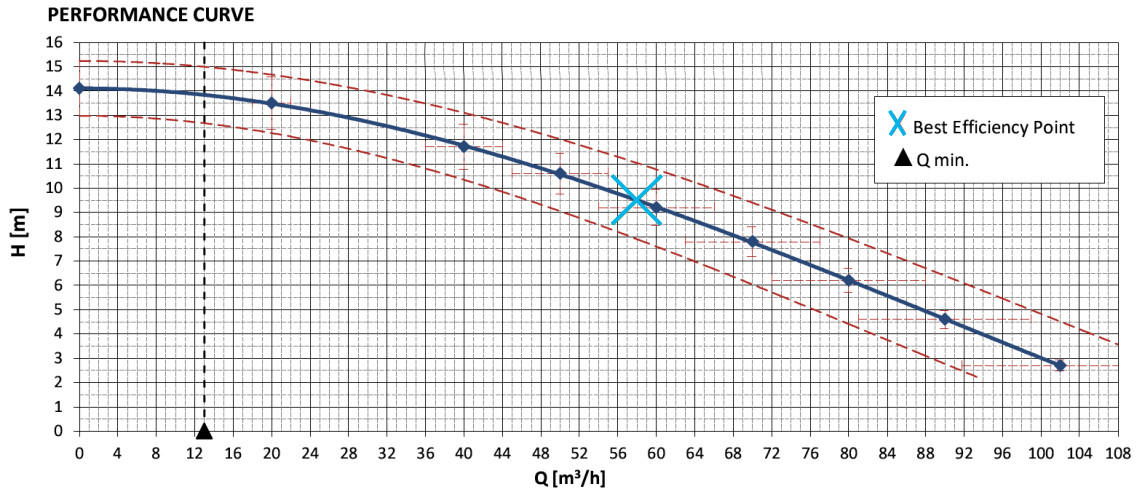

FLOW (Q)	l/min	0,0	333,3	666,7	833,3	1000,0	1166,7	1333,3	1500,0	1700,0			
	l/s	0,0	5,6	11,1	13,9	16,7	19,4	22,2	25,0	28,3			
	m ³ /h	0,0	20,0	40,0	50,0	60,0	70,0	80,0	90,0	102,0			
HEAD (H)	m	14,1	13,5	11,7	10,6	9,2	7,8	6,2	4,6	2,7			

Specifications

Pump Type	VX80T	Discharge	80mm BSP	Humidity Probe	Yes
Code	VX80T4.942	Power Supply	3ph 400V - 50Hz	Cable Length	10m
Construction	Cast Iron	Nominal Speed	1450rpm	Max Flow	102m ³ /hr
Impeller Type	Vortex	Rated Motor Power	4.9kW	Max Head	14.1m
Weight	108kg	Starting Current	44.5A	Ingress Rating	IP68
Impeller diameter	220mm	Rated Current	8.1A		
Solids Passage	80mm	Thermal Protection	Yes		

Vortex Submersible Pump

VX80T4.942



Dimensions and installation

S Installation mobile

UNI EN 1092-1
DN80 PN10

12x \varnothing 18

\varnothing 81

\varnothing 160

Packaging dimensions

Measures [mm]

A	B	C
750	450	390

FC With foot coupling

REF.

563,5

322

81

2x \varnothing 1 1/2

171

345

108

756

334

S1: 747

321

180

55

95

2x \varnothing 18

327

160

220

240

66

94

UNI EN 1092-1
DN80 PN10

12x \varnothing 19

4xR9

8FC00004 **KG: 30**

1	1 1/2" guide rails bracket
2	Vertical foot - 3"out
3	Sliding bracket complete
4	Not supplied

D 550

E 600

F 400